

HC1-A User's Manual

Series Variable Frequency AC motor Drive



TECORP Drive

Complete Range

220V class 0.4 ~ 45KW (1 ϕ / 3 ϕ)

400V class 0.75 ~ 450KW (3 ϕ)

Contents

1. Introduction-----	1
1.1 Confirmations upon delivery -----	2
1.2 Nameplate information -----	2
2. Safety Precautions -----	2
2.1 Before delivery of current-----	2
2.2 In delivery of current -----	4
2.3 In running -----	4
3. Inverter standard specifications -----	4
3.1 Individual specifications -----	4
3.2 Common specifications -----	6
4. Storage & Installation -----	7
4.1 Storage-----	7
4.2 Location -----	7
4.3 Position -----	8
5. Wiring -----	9
5.1 Main circuit schematic diagram-----	9
5.2 Terminals -----	10
5.3 Standard Connection Diagram-----	12
5.4 Wiring Precautions -----	13
6. Using the digital operator-----	15
6.1 Explanations of the digital operator-----	15
6.2 Display data -----	17
6.3 Instructions of the digital operator -----	18

7. Trial Operation ----- 19
7.1 Inspection before operation ----- 19
7.2 Trial operation procedures ----- 19
8. Function List ----- 20
9. Explanations of the functions ----- 27
10. Maintenance, Inspection & Trouble shooting ----- 72
10.1 Precautions about maintenance and inspection ----- 72
10.2 Regular Inspection items ----- 72
10.3 Error information and its troubleshooting ----- 74
10.4 Error and its analysis ----- 75
11. Peripheral devices and specifications of options ----- 77
11.1 Peripheral devices ----- 77
11.2 Proper specifications of options ----- 78
12. Appendices ----- 81
12.1 Application demonstrations ----- 81

This operation manual is 1.37 versions. Specifications are subject to change without notice for ongoing modifications and improvements.

1. Introduction

Thank you for purchasing our high quality HC1-A series inverters.

Before installation and operation please read these instructions in this manual thoroughly. For your safety, the product should only be installed, tested and adjusted by professional personnel. If you have any questions or problems, please contact our local agency.

The information contained in this manual is subject to change without notice.

 **WARNING** Indicates precautions that, if not avoided, could result in death or serious injury to personnel.

 **CAUTION** Indicates precautions that, if not avoided, could result in minor or moderate injury to personnel and damage to equipment.

WARNING

- Always turn off the input power supply before wiring.
- Do not touch any inner part of the inverter when the charging lamp is still on shortly after the AC power is cut off.
- Do not check signals while the inverter is running.
- Do not attempt to modify or alter the inverter by yourself, doing so can result in electrical shock or injury or even explosion.
- Be sure to ground the E terminal.

CAUTION

- Do not perform voltage withstand tests on the inverter.
- Never connect the AC main circuit power supply to output terminals U.V and W.
- A CMOS IC is used in the control board. Handle the control board and CMOS IC carefully. The CMOS IC can be destroyed by static electricity if touched directly.
- Installation, testing and maintenance must be performed by professional personnel.
- The inverter should be discarded as industrial waste. Avoid burning.

1.1 Receiving

Before unpacking please check the following:

- Inspect the entire exterior of the inverter to see there are any scratches or other damage resulting from shipping.
- Check if there is an inverter and an operation manual in the package as soon as you open the package.
- Check the model on the nameplate on the side of the inverter to see if this is the right model you want.
- Check if there is something wrong with the inner parts, wiring and circuit board.
- Use a screwdriver or other tools to check for tightness.
- Check if there is any other things in the machine.
- Check if the operator buttons are all right.
- Check if the optional device you ordered is contained in it.

1.2 Nameplate information

MODEL:	HC1A07D543B
INPUT:	3 Ph 400V 50/60Hz
OUTPUT:	3 Ph 400V 17.5A 7.5KW
Freq- Range:	0.1 ~ 400Hz
TECORP ELECTRONICS CO., LTD.	

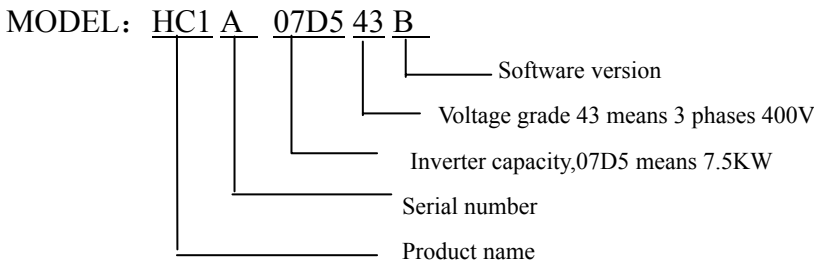

2.Safety precautions

2.1 Before delivery of current

▲ CAUTION

- Check to be sure that the voltage of the main circuit AC power supply matches the rated voltage of the inverter.

▲ CAUTION

- E symbol is the ground terminal, Be sure to ground the ground terminal.
- Do not Connect electromagnetic switches or contactors to the output circuits.

▲ WARNING

- R.S.T terminals are power input terminals, never mixed with U.V.W terminals. Be sure that the wiring of the main circuit is correct.

▲ CAUTION

- Always hold the case when carrying the inverter. If the inverter is held by the front cover, the main body of the inverter may fail, possible resulting in injury.
- Mount the inverter to a metal or other noncombustible material.
- Install the inverter in a safe site, avoid high temperature, direct sunlight, humid air or water.
- Keep the inverter from the reach of children or non-workers.
- Install a cooling fan or other cooling device when installing more than one inverters in the same enclosure so that the temperature of the air entering the inverter is below 40°C.

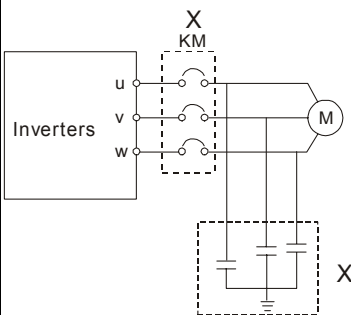

- Check to be sure that the front cover is attached before turning on the power supply. Do not remove the front cover during operation.
- Do not install the inverter in a space with explosive gas.
- If the inverter is used at or above 1000m above seal level, the cooling efficiency will be worse, so please run it downgraded.

- Do not connect contactors and related capacitor or voltage dependent resistor etc, to the output circuits.
- If it is a must to connect such devices, be sure there is no inverter output when operating these devices. Otherwise, it will result in damage

to the inverter. The installation diagram like this is forbidden.

- Do not connect contactor to the input circuits. The service life of the inverter can be much longer if you start or stop the inverter by pressing the buttons FOR or REV, especially in those frequently starting and stop conditions.

2.2 In delivery of current

WARNING

- Do not remove connectors on the inverter when in delivery of current.
- Always have the protective cover in place before delivery of current to avoid electrical shock.

2.3 In running

WARNING

- Never add or remove motor group while in running, the surge current it created will cause damage to the inverter, even burn-up of the main circuit.

WARNING

- Never remove the front cover of the inverter while in running.
- Do not come close to the machine when the fault restart function is used. If the alarm is cleared, the machine may start moving suddenly.
- The function of the STOP button can only be available after setting. It is different from the emergency stop button. Please note.

CAUTION

- Do not touch the heat sink, braking resistor, or Braking Resistor Unit. These can become very hot.
- Be sure that the motor and machine is within the applicable ranges before starting operation.
- Do not check the signals while the inverter is running.
- Be careful when changing inverter settings. The inverter has been set to suitable for general using in factory.
- Do consider the noise, vibration, and the speed limit of the motor and the mechanical devices when the inverter is running at or above the frequency of 50Hz.

3. Standard Specifications

3.1 Individual Specifications

MODEL	Input Voltage	Power (KW)	Driver Capacity (KVA)	Output Current (A)	Suitable Motor (KW)
HC1A00D423B	1 Φ / 3 Φ 220V	0.4	1.0	2.5	0.4
HC1A0D7523B	1 Φ / 3 Φ 220V	0.75	2.0	5.0	0.75
HC1A01D523B	1 Φ / 3 Φ 220V	1.5	2.8	7.0	1.5
HC1A02D223B	1 Φ / 3 Φ 220V	2.2	4.0	10	2.2
HC1A0D7543B	3 Φ 400V	0.75	2.2	2.7	0.75
HC1A01D543B	3 Φ 400V	1.5	3.2	4.0	1.5
HC1A02D243B	3 Φ 400V	2.2	4.0	5.0	2.2
HC1A03D743B	3 Φ 400V	3.7	6.8	8.5	3.7
HC1A05D543B	3 Φ 400V	5.5	10	12.5	5.5
HC1A07D543B	3 Φ 400V	7.5	14	17.5	7.5
HC1A001143B	3 Φ 400V	11	19	24	11
HC1A001543B	3 Φ 400V	15	26	33	15
HC1A18D543B	3 Φ 400V	18.5	32	40	18.5
HC1A002243B	3 Φ 400V	22	37	47	22
HC1A003043B	3 Φ 400V	30	52	65	30
HC1A003743B	3 Φ 400V	37	64	80	37
HC1A004543B	3 Φ 400V	45	72	91	45
HC1A005543B	3 Φ 400V	55	84	110	55
HC1A007543B	3 Φ 400V	75	116	152	75
HC1A009043B	3 Φ 400V	90	134	176	90
HC1A011043B	3 Φ 400V	110	160	210	110
HC1A013243B	3 Φ 400V	132	193	253	132
HC1A016043B	3 Φ 400V	160	230	304	160
HC1A018543B	3 Φ 400V	185	260	340	185
HC1A020043B	3 Φ 400V	200	290	380	200
HC1A022043B	3 Φ 400V	220	325	426	220
HC1A025043B	3 Φ 400V	250	368	483	250
HC1A028043B	3 Φ 400V	280	412	540	280

MODEL	Input Voltage	Power (KW)	Driver Capacity (KVA)	Output Current (A)	Suitable Motor (KW)
HC1A030043B	3 Φ 400V	300	450	580	300
HC1A031543B	3 Φ 400V	315	461	605	315
HC1A037543B	3 Φ 400V	375	550	800	375
HC1A041543B	3 Φ 400V	415	610	880	415
HC1A045043B	3 Φ 400V	450	665	960	450

3.2 Common Specifications

ITEM	HC1-A	
Control Method	SPWM	
Input Power Supply	400V Power Supply: 340 VAC - 460VAC 220V Power Supply: 180 VAC – 250 VAC	
Frequency Control	Frequency Range	0.10~400.00Hz
	Frequency Accuracy	Digital: 0.01% (-10~40°C) Analog: 0.1% (25±10°C)
	Frequency Setting Resolution	Digital: 0.01Hz Analog: 1% of Max Operating Frequency
	Output Resolution	0.01Hz
	Operator Setting Method	Press \leftarrow or \wedge or \vee to set
	Analog Setting Method	0-5V / 0-10V 4-20mA / 0-20mA
	Other functions	Frequency up/lower limit, start frequency, stopping frequency, three skip frequencies can be individually set.
General Control	Acceleration/Deceleration time	0.1-6500s four selectable combinations of independent acceleration and deceleration setting.
	V/F Curve	Set V/F curve at will.
	Torque Control	Max Torque 10.0% Max Output Voltage. The starting torque can reach 150% at 1.0Hz
	Multi-function input terminals	6 multifunction input terminals for 8 multi-speed, easy PLC, 4 Accel/Decel time, UP/DOWN command, external emergency stop.

ITEM		HC1-A
Communication Control		RS485
Operating Temperature		-10~40°C
Humidity		0-95% relative humidity
Vibration		0.5G or lower
Protection Function	Instantaneous over current	Approx. 200% rated current.
	Over Load	Inverter: 150% 1 minute.
	Motor Overload Protection	Electronic thermal overload relay.
	Over Voltage	23 series: DC bus over 400Vdc 43 series: DC bus over 800Vdc
	Under Voltage	23 series: DC bus voltage drop 200Vdc 43 series: DC bus voltage drop 400Vdc
	Momentary Power Loss	0-2 seconds: The inverter can be restarted by speed search.
	Heat Sink over heat	Protected by thermistor
Multi-function output terminals	Multi-function output terminals	5 multifunction output terminals for the displaying and warning of on-running, zero speed, counting and external fault information.
	Other functions	AVR, Decelerating stop or free-stop, DC brake, auto restart tracking, easy PLC auto energy saving, adjustable carrier Frequency (Max 20KHz) etc.
Digital operator monitor		Frequency command, output frequency, speed output current, output voltage. DC bus voltage and rotation direction.

4.Storage &Installation

4.1 Storage

This product must be stored in its package box before installation. Pay more attention to the followings when in storage.

- It must be stored in a dry place without rubbish or dust.

- The suitable temperature for storage is between -20°C and $+65^{\circ}\text{C}$.
- The relative humidity required is 0-95%, no condensation.
- There is no corrosive gas or liquid.
- It's better to lay the inverter in its original package on a shelf.

4.2 Location

Note: The working conditions of the inverter will affect its service life, please install the inverter under the following conditions.

- Ambient operating temperature -10°C to 40°C .
- IP rating: IP 20 for all models.
- Protected from rain moisture.
- Shielded from direct sunshine.
- Free from metallic particles and corrosive gas.
- Free from excessive vibration.

4.3 Positioning

- There must be enough space left around the inverter for easy maintenance and effective ventilation. See Diagram 1.
- The inverter must be installed with heat sink ribs oriented vertically for effective ventilation.
- If there is any instability when installing the inverter, please put a flat board under the inverter bottom base and install again. If the inverter is installed on a loose surface, stress may cause damage in main circuit.
- The inverter should be installed on non-combustible materials, such as iron plates.
- If several inverters are installed together in one cabinet, please add heat dissipation plates and provide enough space between the inverters. See Diagram 2.

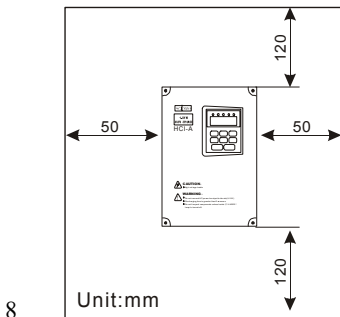

Diagram 1

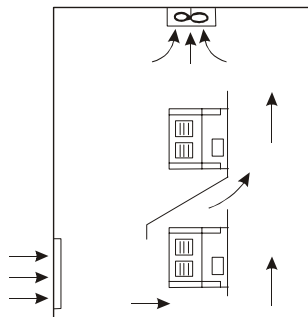

Diagram 2

5. Wiring

5.1 Main circuit schematic diagram



① Power supply: Verify that the inverter rated voltage coincides with AC power supply voltage.



② No fuse breaker or ground fault interrupter.



③ Magnetic contactor

Note: Don't use the magnetic contactor as the power supply on/off button for the inverter.



④ AC reactor for power factor improvement.



⑤ TECORP Inverter (HC1-A series)

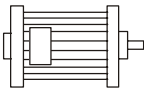

⑥ 3 phases squirrel cage induction motor.

5.2 Terminals

5.2.1 Main Circuit Terminals Arrangement

HC1A00D423B-HC1A02D223B

HC1A0D7543B-HC1A03D743B

E	R	S	T	U	V	W	P	Pr
⊕	⊕	⊕	⊕	⊕	⊕	⊕	⊕	⊕

HC1A05D543B-HC1A07D543B

E	R	S	T	U	V	W	P ₁	P	PR
⊕	⊕	⊕	⊕	⊕	⊕	⊕	⊕	⊕	⊕

HC1A001143B-HC1A030043B

R	S	T	E	P	N	U	V	W
⊕	⊕	⊕	⊕	⊕	⊕	⊕	⊕	⊕

5.2.2 Control circuit terminals arrangement

FA	FB	FC		EV	SPL	SPM	SPH	RST	DCM	REV	FOR
KA	KB		UPF	DRV	+10	VI	AI	ACM	AM	RS-	RS+

HC1A00D423B-HC1A01D523B

HC1A0D7543B-HC1A02D243B

FA	FB	FC	KA	KB	IPV	UPF	DRV	DCM	SPL	SPM
----	----	----	----	----	-----	-----	-----	-----	-----	-----

SPH	RST	REV	FOR	+10	VI	AI	ACM	AM	RS-	RS+
-----	-----	-----	-----	-----	----	----	-----	----	-----	-----

HC1A02D223B

HC1A03D743B-HC1A07D543B

UPF	DRV	FOR	REV	DCM	RST	SPH	SPM	SPL	P24	AM
-----	-----	-----	-----	-----	-----	-----	-----	-----	-----	----

ACM	AI	VI	+10		EKB	EKA	EFC	EFB	EFA
-----	----	----	-----	--	-----	-----	-----	-----	-----

HC1A02D223B

HC1A03D743B-HC1A07D543B

5.2.3 Function description of main circuit terminals

SYMBOL	FUNCTION DESCRIPTION
R.S.T	Input terminals of AC line power.
P.Pr	External braking resistor terminals.
P.P ₁	External DC reactor terminals.
P.N	External Braking unit terminals.
U.V.W	Output terminals to motor.
E	Ground terminal.

5.2.4 Function description of control circuit terminals

Symbol	Functions	Factory setting
FOR	Multi-function input1	Forward run
REV	Multi-function input2	Reverse run
RST	Multi-function input3	Reset
SPH	Multi-function input4	High speed
SPM	Multi-function input5	Medium Speed
SPL	Multi-function input6	Low Speed
DCM	Ground common for input terminals	
EV(IPV)	+12V power supply	Max output current 200mA
P24	+24V power supply	Max output current 200mA
+10	Power supply for analog frequency	+10V
VI	Analog frequency reference input(voltage)	0~+10V corresponding to highest operating frequency
AI	Analog frequency reference input(current)	4~20mA corresponding to highest operating frequency
ACM	Common for analog input signal	
DRV	Multi-function output terminal 1	Optical couple output DC 24V/100mA
UPF	Multi-function output terminal 2	
FA(EFA)、 FB(EFB)、 FC(EFC)	Multi-function output terminal 3	Fault Relay output(N/O or N/C) 3A/250VAC,3A/30VDC
KA(EKA)、 KB(EKB)	Multi-function output terminal 4	Fault Relay output (N/O) 3A/250AC,3A/30VDC
AM	Digital frequency output terminal	0-10V
RS+RS-	RS-485 communications	

5.3 Standard Connection Diagram

The whole wiring is divided into two parts. Main circuit terminal connections and control circuit terminal connections. Users can see the main circuit terminals and the control circuit terminals after removing the outer cover. The terminals must be connected correctly as the following diagrams.

The following diagram shows the standard connection of HC1-A.

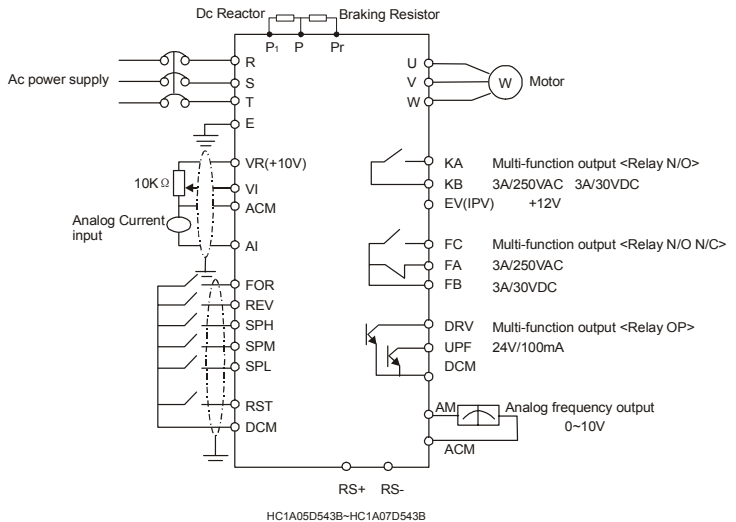
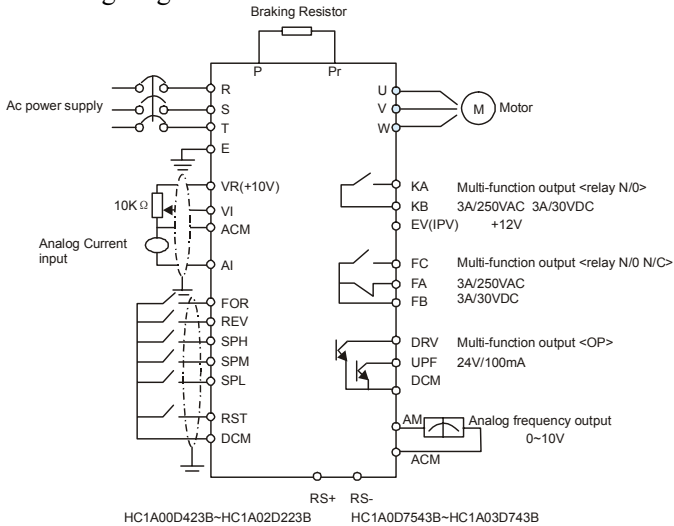

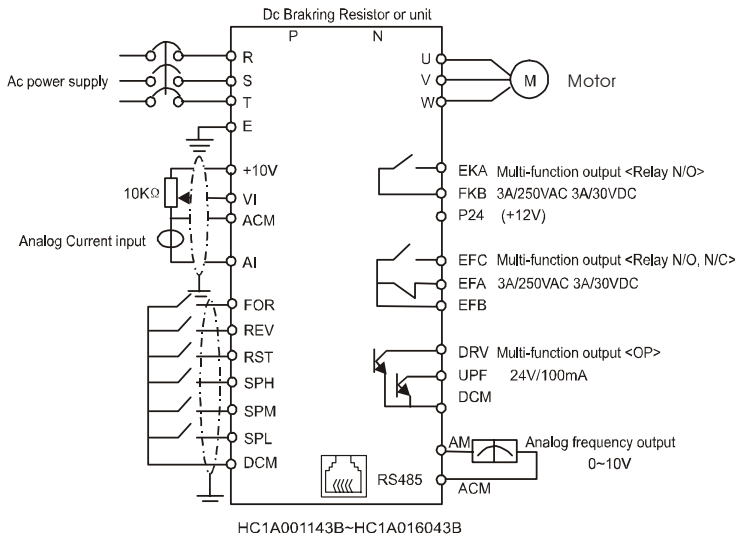

5.4 Cautions on Wiring

5.4.1 For main circuit wiring

● No Fuse Breaker between the power supply and the input terminals (R.S.T).

(If using ground fault interrupter, please choose the one corresponding to high frequency)

● Never connect AC power to the output terminals of U.V.W on the inverter.

● Output wires mustn't be in touch with the metal part of the outer cover, or it will cause short-circuit.

● Phase-shifting capacitor, LC, RC noise filters, etc, can never be connected between motor and output terminals (U.V.W)

● The main circuit wire must be enough far away from other control equipments.

● If there is a relatively long distance between the inverter and the motor, please lower the carrier frequency. Because the high leak current will cause damage to the inverter and other equipments.

● If the wire is more than 15m for 220V class products (or 30m for

400V class products) between the inverter and the motor, please choose a AC motor special for inverters or add a AC reactor on the output side of the inverter, because a very high dV/dT produced in the motor coil will cause damage to the insulation of the motor.

Specifications for NFB and Wire

	Model	Screw	Wire size
220V Class	HC1A00D423B	M4	2~5.5
	HC1A0D7523B	M4	2~5.5
	HC1A01D523B	M4	2~5.5
	HC1A02D223B	M4	3.5~5.5
	HC1A03D723B	M4	5.5
400V Class	HC1A0D7543B	M4	2~5.5
	HC1A01D543B	M4	2~5.5
	HC1A02D243B	M4	2~5.5
	HC1A03D743B	M4	3.5~5.5
	HC1A05D543B	M4	3.5~5.5
	HC1A07D543B	M5	5.5
	HC1A001143B	M6	8
	HC1A001543B	M6	8
	HC1A18D543B	M6	14
	HC1A002243B	M8	22
	HC1A003043B	M8	22
	HC1A003743B	M8	30
	HC1A004543B	M8	50
	HC1A005543B	M8	38~100
	HC1A007543B	M10	38~100
	HC1A009043B	M10	38~100
	HC1A011043B	M10	60~100
	HC1A013243B	M12	60~100
	HC1A016043B	M12	100~200
	HC1A018543B	M16	250~325
HC1A022043B	M16	325	
HC1A030043B	M16	250*2p	

Note: The parameters above are only for reference, not a standard.

5.4.2 For control circuit wiring (signal line)

- Separate control circuit wire from main circuit wire and other high-power lines.
- Use twisted-pair or shielded twisted-pair cables for control circuits to prevent operating faults. The size should be 0.5-2mm².

- Use the control terminals correctly according to your needs.

5.4.3 Grounding

- Grounding terminal: E

220V class: The third grounding method. (grounding resistance should be 100 ohm or lower.)

380V class: Special grounding method. (earth resistance should be 10 ohm or lower.)

- Choose grounding wires according to the requirements of the electric equipment.
- Avoid sharing grounding wire with other large power equipment. The grounding wire should be kept away from the power supply wires.
- The grounding method for several inverters together should be done as the first and second diagrams. Avoid the third diagram.
- The shorter grounding wire is the better it is.

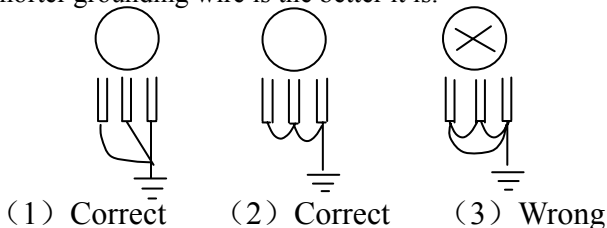

6. Description of Digital Operator

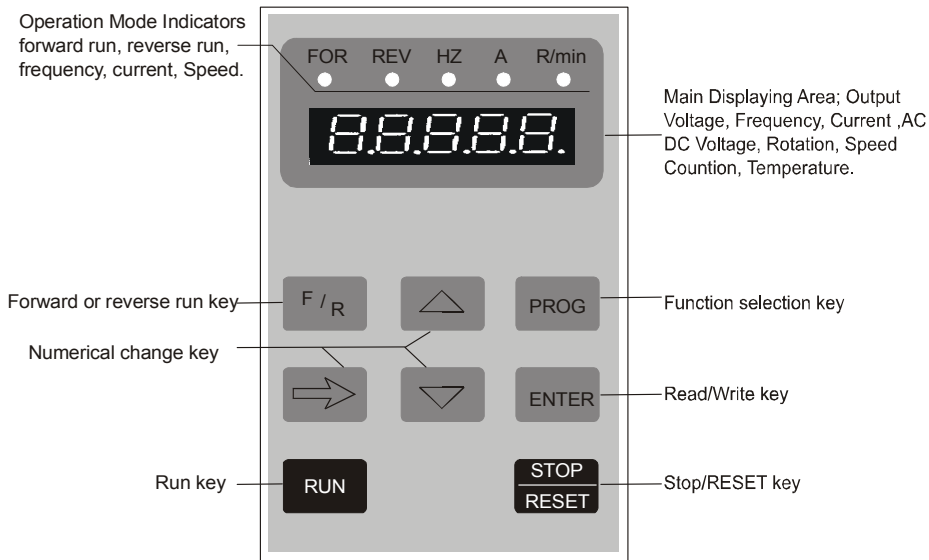

HC002

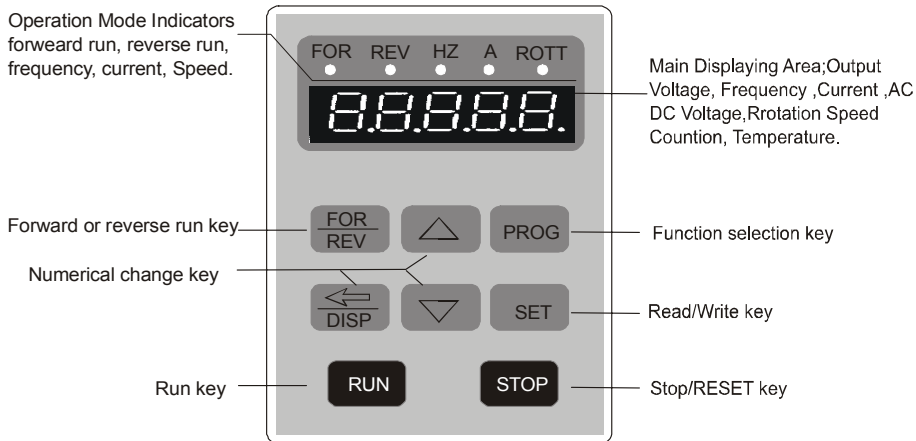

HC001

6.2 Display status

6.2.1 Display status description

Indicator	Status	Explanation
FOR	On	Forward run
REV	On	Reverse run
HZ	On	Display set frequency or output frequency
A	On	Display output current
ROTT	On	Display motor speed
HZ A	On	Display DC voltage
A ROTT	On	Display output voltage
HZ ROTT	On	Display counting data
HZ A ROTT	On	Display inverter temperature

6.2.2 Explanation to data display

Display item	Indicator □ on	Explanation
050.00	HZ □	Present set frequency or output frequency
5.5	A □	Current
1440	ROTT □	Motor speed
30.0	HZ A ROTT □ □ □	Present inverter heat sink temperature
CD100	HZ □	Function item
EOC.A		Error information

6.3 Operation Example

Procedures	Data	Display	Explanation
Power on ↓	dsp.1 flashing →uEr1.3 →000.00	FOR Hz ● ✕	Self inspection after power on, showing its version number (flashing), then its set frequency.
PROG ↓	CD000	FOR Hz ● ✕	Function number Cd000.
ENTER	000.0✕	FOR Hz ● ✕	Display the value of Function CD000.
▲ ↓ ← ENTER ↓ PROG	✕0.00 END→50.00 CD00✕ 050.0✕	FOR Hz ● ✕ FOR Hz ● ✕	Modify the value of Function CD000. Display:END→50.00 →CD001 Withdraw from the programming status.
↓ RUN	50.00	FOR Hz ✕ ✕	Display:Forward run status and set frequency.
↓ ← DISP	50.00 0.00→50.00	FOR Hz ✕ ✕	Switching to display running frequency.
↓ ← DISP	0005.0	FOR A ✕ ✕	Switching to display output current.
↓ ← DISP	01440	FOR ROTT ✕ ✕	Switching to display rotating speed.
↓ PROG	050.00	FOR Hz ✕ ✕	Return to main display, showing set frequency.
↓ F/R	050.00	REV Hz ✕ ✕	FORWARD RUN/REVERSE RUN shift, display "reverse run" status.
↓ ▲	050.0✕	REV Hz ✕ ✕	Switching to frequency adjustable status.
↓ ← ▲	0✕0.00	REV Hz ✕ ✕	Adjust the set frequency, that is the value of CD000.
↓ ENTER	030.00	REV Hz ✕ ✕	Enter the new value which will be remembered as CD000.
↓ STOP	0✕0.00	REV Hz ● ✕	Stop.

Note: (1) means flashing ◐means on

7. Trial Operation

7.1 The important check before running

● Is there any wrong connected wires? Pay special attention to the terminals: U.V.W;

Make sure the power supply wires are connected to R.S.T not U.V.W.

● Is there any metal powder or other wires left on the base plate of the inverter or at the terminals?

● Is there any looseness in the parts of screws and terminals?

● Is there any short circuit or earth fault in the output parts?

7.2 Trial operation procedures

Trial operation can be carried out by the digital operator.

Generally, trial operation is done at 5.00 Hz.

Procedures	Data Display	Indicator	Explanations
POWER ON ↓	dsp1.1 → uEr1.3 ϕϕϕ.ϕϕ	FOR Hz ● □	Self inspection after power on, display version number, at last display set frequency.
△	000.0ϕ	FOR Hz ● □	Switching to data adjustable status.
↓ ←△	050.00	FOR Hz ● □	Set a new frequency value that is the new CD000 value.
↓ ENTER	ϕ5ϕ.ϕϕ	FOR Hz ● □	Confirm this new setting.
↓ RUN	050.00	FOR Hz □ □	Running at 50Hz.
↓ STOP	ϕ5ϕ.ϕϕ	FOR Hz ● □	Stop.

Note: □ means indicator on, ● means indicator flashing

ϕ Means the number flashing

8.Function list

Parameter and Function List (Part 1)

Item	Function code	Function	Set range&function explanation	Factory Setting
Basic parameter	CD000	Main frequency	0.00~400.00Hz	0.00
	CD001	Max output voltage	0.1V—*	220/380
	CD002	Base frequency	0.01~400.00Hz	50.00
	CD003	Voltage at medium frequency	0.1V—*	15/27.5
	CD004	Medium frequency	0.01~400.00 Hz	2.50
	CD005	Voltage at lowest frequency	0.1~50.0V	8.0/13.5
	CD006	Lowest frequency	0.01~20.00 Hz	0.50
	CD007	Max operating frequency	50.00~400.00 Hz	50.00
	CD008	Frequency upper limit	0.01~400.00 Hz	50.00
	CD009	Frequency lower limit	0.00~400.00 Hz	0.00
	CD010	Parameter lock select	0:invalid 1:valid	0
	CD011	Factory setting	00~10 only No.08 means to reset to factory setting	00
	CD012	Accel.Time 1	0.1~6500.0S	10.0/25.0
	CD013	Decel.Time 1	0.1~6500.0S	10.0/25.0
	CD014	Accel.Time 2	0.1~6500.0S	50.0
	CD015	Decel.Time 2	0.1~6500.0S	50.0
	CD016	Accel.Time 3	0.1~6500.0S	100.0
	CD017	Decel.Time 3	0.1~6500.0S	100.0
	CD018	Accel.Time 4	0.1~6500.0S	200.0
	CD019	Decel.Time 4	0.1~6500.0S	200.0
CD020 ∫ CD030	Reserved			

Parameter and Function List (Part 2)

Item	Function code	Function	Set range &function explanation	Factory Setting
Applied Parameter	CD031	Start mode	0:start from starting frequency 1:start by former frequency track	0
	CD032	Stop mode	0:decelerate to stop 1:free run to stop	0
	CD033	Control Mode Select	0:digital operator 1:external terminals 2:communications	0
	CD034	Frequency command method select	0:digital operator 1:external terminals 2:communications	0
	CD035	Carrier frequency	0~15	5
	CD036	Jog frequency	0.00~400.00Hz	5.00
	CD037	FOR/REV select	0:Reverse run forbidden 1:Reverse run available	1
	CD038	“STOP”key definition	0:STOP key ineffective in remote control mode 1:STOP key effective in remote control mode	
	CD039 ∫ CD040	Reserved		
	CD041	Starting Frequency	0.1~10.0Hz	0.5
	CD042	Stopping Frequency	0.1~10.0Hz	0.5
	CD043	Torque Boost	0—10%	2.0%
	CD044	Skip Frequency 1	0.00~400.00 Hz	0.00
	CD045	Skip Frequency 2	0.00~400.00 Hz	0.00
CD046	Skip Frequency 3	0.00~400.00 Hz	0.00	

Parameter and Function List (Part 3)

Item	Function code	Function	Set range &function explanation	Factory Setting
Applied Parameter	CD047	Skip Frequency Range	0.00~2.00 Hz	0.5
	CD048	Reserved		
	CD049			
Input, Output Terminals	CD050	Multi-input 1 (FOR)	00:invalid 01:run 02:forward run 03:reverse run 04:stop	02
	CD051	Multi-input 2 (RST)	05:for/rev run 06:jog	03
	CD052	Multi-input 3 (RST)	07:forward jog 08:reverse jog	10
	CD053	Multi-input 4 (SPL)	09:external emergency stop	17
	CD054	Multi-input 5 (SPL)	10:reset 11:reserved	18
	CD055	Multi-input 6 (SPL)	12:overheat of motor 17:high speed 18:medium speed 19:low speed 20:multi-speed1 21:multi-speed2 22:multi-speed3 23:accel/decel select1 24:accel/decel select2	19
	CD056	Multi-output 1 (DRV)	00:Invalid 01:run mode 02:Fault signal 03:zero speed	01
	CD057	Multi-output 2 (UPF)	04:Brake indication 05:Up to setting frequency 06:Up to desired frequency1	05
	CD058	Multi-output 3 (FA FB FC)	07:Up to desired frequency2 08:In accelerating 09:In decelerating 10:Inverter overload 11:Motor overload 13:Under voltage 14:Finish indication for single stage 15:Finish indication for process 16:counting arrival 27:Drafting arrival 28:PID lower limit alarm 29:PID upper limit alarm 30:Fan running 31:Reserver 32:Braking resistor action	02
	CD059	Multi-output 4 (KA KB)		00
	CD060	Multi-output 5 (AM)		1
CD061	UP-to desired frequency1 setting	0.00~400.00Hz		

Parameter and Function List (Part 4)

Item	Function code	Function	Set range & function explanation	Factory Setting
Input Output Terminals	CD062	UP-to desired frequency 2 setting	0.00~400.00 Hz	0.00
	CD063	UP-to frequency setting detection width	0.10~10.00 Hz	0.50
	CD064	Counter set	00~65500	00
	CD065	Analog input select	0:0~10V 1:0~5V 2:0~20mA 3:4~20mA 4:0~10V plus 4 ~ 20mA	0
	CD066	Lower analog frequency set point	0.00~400.00Hz	0
	CD067	Lower analog frequency bias direction	0:positive 1:negative	0
	CD068	Higher analog frequency set point	0.00~400.00Hz	50.00
	CD069	Higher analog frequency bias direction	0:positive 1:negative	0
	CD070	Negative bias reverse select	0:invalid 1:valid	1
	CD071	Analog output gain	0.0~100.0%	100
	CD072	Up/down function select	0:recorded 1:non-recorded	1
	CD073 ∫ CD075	Reserved		

Parameter and Function List (Part 5)

Item	Function code	Function	Set range & function explanation	Factory setting
Multi-section speed and simple PLC	CD076	PLC mode select	0:normal running 1:externalcontrol four speed 2:external control multi speed 3:disturbance 4:inner control multi speed	0
	CD077	Auto PLC select	0:stop after one circle 1:circulating running 2:stop after auto running one circle (with STOP interval) 3:auto circulating running (with STOP interval)	0
	CD078	PLC running direction	0~255(0:Positive 1:Negative)	0
	CD079	PLC accel/decel.time	0~65535	0
	CD080	Multi-speed 2	0.00~400.00Hz	15.00
	CD081	Multi-speed 3	0.00~400.00Hz	20.00
	CD082	Multi-speed 4	0.00~400.00Hz	25.00
	CD083	Multi-speed 5	0.00~400.00Hz	30.00
	CD084	Multi-speed 6	0.00~400.00Hz	35.00
	CD085	Multi-speed 7	0.00~400.00Hz	40.00
	CD086	Multi-speed 8	0.00~400.00Hz	0.50
	CD087	Timer 1	0.0~6500.0s	10.0
	CD088	Timer 2	0.0~6500.0s	10.0
	CD089	Timer 3	0.0~6500.0s	0.0
	CD090	Timer 4	0.0~6500.0s	0.0
	CD091	Timer 5	0.0~6500.0s	0.0
	CD092	Timer 6	0.0~6500.0s	0.0
	CD093	Timer 7	0.0~6500.0s	0.0
CD094	Timer 8	0.0~6500.0s	0.0	
CD095 ∫ CD119	Reserved			

Parameter and Function List (Part 6)

Item	Function code	Function	Set range & function explanation	Factory setting
Protective function parameter	CD120	Stall prevention select	0:invalid 1:valid	1
	CD121	Stall prevention level during accel	0~200%	150
	CD122	Stall prevention level during running	0~200%	0
	CD123	Stall prevention level during decel	0~200%	150
	CD124	Reserved		
	CD125	Over torque detection level	0~200%	1.0
	CD126	Over torque detection time	0.1~20.0s	
	CD127 ∫ CD129	Reserved		
Motor specifications	CD130	Rated voltage	According to the motor nameplate	*
	CD131	Rated current	According to the motor nameplate	*
	CD132	Motor poles	02—10	1440
	CD133	Rated rotational speed	00—9999	
	CD134 ∫ CD139	Reserved		
Special function parameter	CD140	DC braking level	0.0~20.0%	2.0
	CD141	DC braking time at starting	0.0~25.0S	0.0
	CD142	DC braking time at stopping	0.0~25.0S	0.0
	CD143	Speed search time	0~20.0S	5.0
	CD144	Speed search current level	0~200%	150
	CD145	Power loss allowable	0:invalid 1:restart by	0
	CD146	Momentary power ride through time	speed search 0.1~5.0s	0.5
	CD147	Number of auto restart	0—10	00
	CD148	Auto voltage regulation	0:invalid 1:valid	1
CD149	Auto energy saving	0~10%	0	

Parameter and Function List (Part 7)

Item	Function code	Function	Set range & function explanation	Factory setting
Special function parameter	CD150	P	0.0—1000.00%	100%
	CD151	I	0.1~3600.00s	5.0
	CD152	D	0.01~10.00s	
	CD153	Target Value	0.0~100.0%	
	CD154	Target Value Source	0:digital operator 1:external terminals	* *
	CD155	PID Upper Limit	0~100%	100%
	CD156	PID Lower Limit	0~100%	0%
Communication Function	CD157 ∫	Reserved		
	CD159			
	CD160	Communication identified NO	0~250	0
Monitor Parameter	CD161	Baud rate of communication	0~3	1
	CD162	Communication agreement	0—5	0
	CD163 ∫	Reserved		
	CD167			
	CD168	Display mode select	0—15	00
CD169	Rated voltage of the inverter	According to the actual model	* *	
CD170	Rated current of the inverter	According to the actual model	*	
CD171	Software version		—	
CD172	Fault Record 1	Note:—means no fault record	—	
CD173	Fault Record 2		—	
CD174	Fault Record 3		—	
CD175	Fault Record 4		—	
CD176	Fault cleared	00—10 (01 is fault cleared)	00	
Factory Setting	CD177	Reserved		
	CD178	Frequency standard of the inverter	0:50Hz 1:60Hz	0
	CD179	Manufacture Date	Factory Set	*
	CD180	Sequence Number		*
	CD181 ∫ CD250	Reserved		

9. Detail Explanations of the Function

CD000 Main frequency

Set range:0.00—400.00Hz Unit:0.01Hz Factory setting:0.00

In the digital operator method. The inverter will run at the setting value of CD000.During running, users can press the ▲ or ▼ key to change the running frequency. During multi-speed running, the main frequency is the first speed frequency.

In the external terminals method. The inverter will run at the analog reference frequency decided by the external terminals.

Main frequency is limited by Max.Operating frequency.

Related parameter: CD034, CD076, this setting can be change during running.

CD001 Max output voltage

Set range:0.1—* Unit:0.1V Factory setting:220/400V

This value is set according to the rated value on the nameplate of the motor. Factory setting for 400V class is 400V, 220V class is 220V.

This setting is limited by the voltage grade of the inverter. If the motor is a little far away from the inverter, users can properly raise its set value to make up the voltage loss caused by the long distance.

CD002 Base frequency

Set range:0.01—400.00Hz Unit:0.1Hz Factory setting:50.00

This value must be set according to the rated frequency shown on the nameplate of the motor. Under most circumstances, please don't change the set value. If matching a special motor, please change the set value carefully and properly according to the motor characteristics.

CD003 Voltage at medium frequency

Set range:0.1—500.0V Unit:0.1V Factory setting:15/27.5

This parameter can set any medium voltage in the V/F curve. If it is set improperly, it will cause motor over current or deficient torque, or even an inverter tripping. The set value for 220V class inverter is 15.And the set value for 400V class inverter is 27.5.

This set value is limited by the Max voltage value. When the voltage at medium frequency increases to certain value, torque boost will be ineffective. So when adjusting this setting, users should according to the actual load slowly increases the value to match the starting requirements. Don't increase it by a big margin.

CD004 Medium frequency set

Set range:0.01—400.0Hz Unit:0.01Hz Factory setting:2.50

This parameter can set any medium frequency in the V/F curve. If users set improperly, it will cause motor over current or deficient torque, or even an inverter tripping. This set value is limited by the base frequency.

CD005 Voltage at lower frequency

Set range:0.1—50.0V Unit:0.1V Factory setting:8/13.5

This parameter sets the lowest starting voltage in the V/F curve.

This set value for 220V class inverter is 8.And the set value for 400V class is 13.5.

This set value is limited by the voltage at the highest operating frequency.

CD006 Lowest frequency set

Set range:0.1—20.00Hz Unit:0.01Hz Factory setting:0.50Hz

This parameter set the lowest starting frequency in the V/F curve.

CD007 Highest operating frequency

Set range:50.00—400.0Hz Unit:0.01Hz Factory setting:50.00Hz

This parameter set the highest operating frequency of the inverter.

The following curves and set value are for your reference.

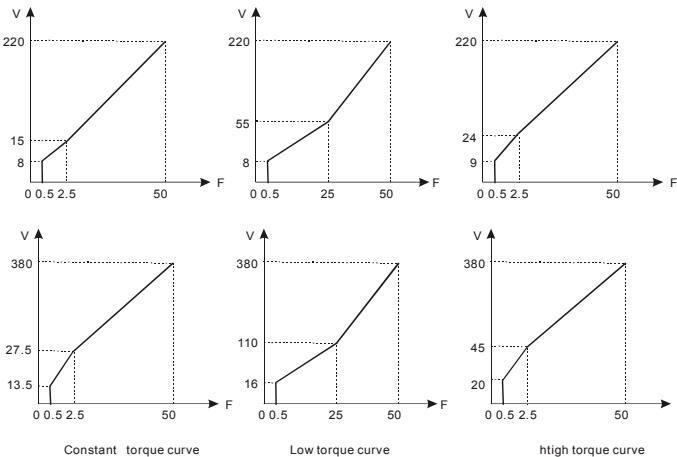

CD008 Frequency upper limit **
Set range:0.01—400.00Hz Unit:0.01Hz Factory setting:50.00Hz

This is set for preventing workers from false operation, avoiding and mechanical abrasion caused by high speed, or other damage.

CD009 Frequency lower limit **
Set range:0.00—400.00Hz Unit:0.01Hz Factory setting:0..00Hz

This is set for preventing workers from false operation, avoiding overheat or some other mechanical faults caused by the too low running frequency.

This set value must be lower than the frequency upper limit.

CD010 Parameter lock select **
Set range:0—1 Unit:1 Factory setting:0

0: invalid

1: valid (which means the other parameters have been locked and unchangeable)

This function can prevent other personnel from changing your set value.

CD011 Factory setting
Set range:00—10 Unit:1 Factory setting:00

If the parameter you have set is improper or abnormal. You can change it into 08 first to return to the factory setting, and then reset it. But if CD010 is set for 1, you should unlock the parameter first. Related parameter: CD010.

CD012 Accel.Time 1 **
Set range:0.1—6500.0s Unit:0.1s Factory setting:10.0/25.0

CD013 Decel.Time 1 **
Set range:0.1—6500.0s Unit:0.1s Factory setting:10.0/25.0

CD014 Accel.Time 2 **
Set range:0.1—6500.0s Unit:0.1s Factory setting:50.0

CD015 Decel.Time 2	**
Set range:0.1—6500.0s	Unit:0.1s Factory setting:50.0

CD016 Accel.Time 3	**
Set range:0.1—6500.0s	Unit:0.1s Factory setting:50.0

CD017 Decel.Time 3	**
Set range:0.1—6500.0s	Unit:0.1s Factory setting:50.0

CD018 Accel.Time 4	**
Set range:0.1—6500.0s	Unit:0.1s Factory setting:50.0

CD019 Decel.Time 4	**
Set range:0.1—6500.0s	Unit:0.1s Factory setting:50.0

Accelerating Time means time needed for inverter accelerating from 0Hz to 50Hz (See t1 in the diagram)

Decelerating Time means time needed for inverter decelerating from 50Hz to 0Hz (See t2 in the diagram)

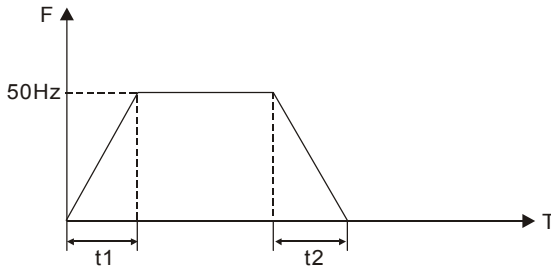

HC1-A Series of inverters have 4 accelerating time and 4 decelerating time. F Accel.time 2.3.4/Decel.time 2.3.4 can be controlled by on/off signal of external input terminals according to actual needs. In the inner-controlled multi-speed running, Accel/Decel time can be controlled by simple PLC.

Generally, the inverter accepts the first accelerating and decelerating time which has been set by the factory according to actual models as below. Inverters of 7.5KW or lower: 10 seconds; Inverters from 11KW to 37KW:25 seconds; Inverters of 55KW or higher: 60 seconds.

Related setting: CD050—CD055 CD078

CD020—CD030 Reserved

CD031 Starting method select
 Set range: 0—1 Unit: 1 Factory setting: 0

Two starting methods are available for different equipment.

0: means start from the starting frequency.

When CD141 is set for “0.0” (meaning: DC brake is invalid), it starts at its starting frequency. When CD141 is set for any other parameters, it will first have a DC braking, and then start from the starting frequency.

Related setting referring to CD040、CD140、CD141.

1: means start by former speed search

This function can be used in the re-starting of large inertia equipment. When re-start, the inverter searches the former speed from set. And when restart, it’s not necessary to wait for the equipment’s complete stop and it can run the executive command right away by doing the former frequency track and save a lot of time.

Note: When the inverter makes a track starting, it will start tracking the frequency from its set frequency, and will make it at the highest speed. When starting, the current will be high, and over current or stall may appear, so the adjustment for current standard position of speed search is important. Generally, CD144 should be set around “100”. The specific value should be set according to actual situation.

Running Command

Output Frequency

Set frequency

Output Current

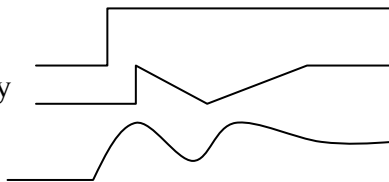

CD032 Stop method select
 Set range: 0—1 Unit: 1 Factory setting: 0

Two stop methods are available for meeting different equipment.

0: means decelerating to stop

When CD142 is set for “0”, DC brake is invalid. When DC brake is invalid, the inverter will decelerate to the stopping frequency, and stop output, the motor will have a free running to final stop. When CD142 is set for any other parameter except “0” (meaning the DC brake is valid), the inverter will first decelerate to the stopping frequency, and then stop finally by DC brake.

The DC brake is usually used in high position stopping or for location control. Special attention should be paid that frequent use of DC brake will cause the motor overheat.

Related setting referring to CD042、CD140、CD142。

1: means free-running to stop

When the inverter receives a “stop”command, it will immediately stop output and the motor will have a free running to stop. When you choose the motor free-running stop method, DC brake is invalid.

CD033 Control Mode Select

Set range: 0—2 Unit: 1 Factory setting: 0

0: controlled by digital operator

The running command is given by digital operator.

1: controlled by external terminals

The running command is given by external terminals
(multi-function input terminals).

2: controlled by the communications

The running command is given by the communications.

CD034 Command Method Select

Set range: 0—2 Unit: 1 Factory setting: 0

0: set by digital operator

The running frequency is set by the digital operator.

1: set by external terminals

The running frequency is controlled by the analog signal through external terminals. The signal type is decided by CD065. Related introduction refer to CD065-CD070。

2: set by the communications

The running frequency is set by serial communications.

CD035 Carrier frequency (Note: 0-15 corresponding to 0-20K Hz)
 Set range: 0—15 Unit: 1 Factory setting: 5

The carrier frequency will affect the electromagnetic noise of the motor, the heating capacity of the inverter and the interference to the environment. See the following table:

Carrier frequency	Electromagnetic noise	Heating capacity	Interference to the environment
low ↓ high	loud ↓ low	small ↓ large	little ↓ strong

Carrier frequency corresponding table:

Set value	0	1	2	3	4	5	6	7	8	9	10	11	12	13	14	15
Carrier frequency	0.7	1	1.5	2	3	4	5	7	8	9	10	11	13	15	17	20

From the table above, we can see that with a higher carrier frequency, the electromagnetic noise will be lower, but the interference to other systems and the heating capacity will be larger. So if the inverter is working in a space with high temperature, and the motor load is heavy, carrier frequency should be properly lowered to reduce the heating capacity.

CD036 Jog frequency **
 Set range: 0.00—400.00 Unit: 0.01 Factory setting: 5.00

This parameter can realize the jog function in trial running. It is controlled only by the external terminals (the multi-function input terminals). The jog frequency is limited by the Max and Min frequency. When the jog function is acting, other running commands are not acceptable. The accelerating time of jog frequency is determined by the first accelerating time. After relaxing the jog button the inverter will immediately stop output. When running in jog function, please set the corresponding multi-function terminal at 07 or 08. The jog function can

only be executed when the machine is in the stop state. It will not be effective when in running. Related setting refers to CD050-CD055.

CD037 Selection for For/Rev Run

Set range: 0—1 Unit: 1 Factory setting: 1

0: Forward Run only. Reverse Run is forbidden.

1: Reverse Run is available.

This function is suitable for the motor which cannot allow reverse rotation. It prevents workers from false operation. When the reverse rotation is forbidden, the motor will not have reverse rotation, only forward rotation.

CD038 “Stop” key valid or not

Set range: 0—1 Unit: 1 Factory setting: 1

0: the command of STOP is invalid.

1: the command of STOP is valid.

This parameter set is only valid when CD033 is set for 1 or 2.

When the control method is set to external terminals or communications, the “stop” key can be chosen to be valid or not.

When you choose it as valid, you can stop the running inverter by pressing the “stop” key. When it needs restarting, the former running signal should be released first.

CD039~CD040 Reserved

CD041 Starting frequency

Set range: 0.1—10.0Hz Unit: 0.1Hz Factory setting: 0.5

Starting frequency is the initial frequency when the inverter begins to work. If the starting frequency is set for 4.0Hz, the inverter will begin to run at 4.0Hz, and later between 4Hz and its Max operation frequency. (The actual Max operation frequency is confined to the lower/upper limit of the frequency).

Related setting refer to: CD031, CD140, CD141

CD042 Stopping frequency

Set range: 0.1—10.0 Hz Unit: 0.1Hz Factory setting: 0.5

When the inverter receives a stop command, it will immediately decelerate to the stopping frequency, stop output or start DC brake to a final stop.

If CD142 is set for “0”, the inverter will stop output DC brake is invalid when it decelerate to the stopping frequency

If CD142 is set for any other parameter except “0”, DC brake is valid; the inverter will stop by DC braking. When it decelerate to the stopping frequency.

Related setting refer to CD032、CD140、CD142。

CD043 Torque Boost

Set range: 0.1—20.0% Unit: 0.1% Factory setting: 2.0

This parameter setting can make the inverter output extra voltage automatically when in running and get a high torque to compensate for the deficit torque when the motor is running in low frequency. The torque boost should not be too large. It should be set gradually from the low point to the high point according to actual situations. If the boost is insufficient it will cause the motor’s torque insufficient at low frequency. But if the boost is too large, it will cause too large torque, which will give impulse to the machinery, and even cause inverter to trip when being serious.

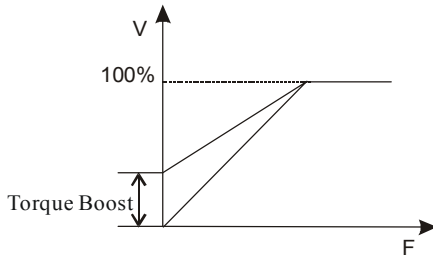

CD044 Skip frequency 1 **

CD045 Skip frequency 2

CD046 Skip frequency 3

Set range: 0.00—400.00 Hz Unit: 0.01Hz Factory setting: 0.0

CD047 Skip frequency range **

Set range: 0.10—2.00 Hz Unit: 0.01Hz Factory setting: 0.5

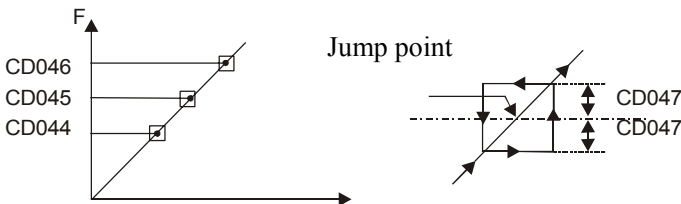

In order to avoid meeting the mechanical resonance point, these three

skip points are set. When CD047 is set for “0”, all the set skip frequencies are invalid; the actual skip frequency range is twice of the setting value of CD047.

Shown as above.

CD048 — CD049 Reserved

CD050	Multi-function Input Terminal 1 (FOR)	Factory setting: 02
CD051	Multi-function Input Terminal 2 (REV)	Factory setting: 03
CD052	Multi-function Input Terminal 3 (RST)	Factory setting: 10
CD053	Multi-function Input Terminal 4 (SPH)	Factory setting: 17
CD054	Multi-function Input Terminal 5 (SPM)	Factory setting: 18
CD055	Multi-function Input Terminal 6 (SPL)	Factory setting: 19
	Set range: 00—32	Unit: 1

ITEM	NAME	DESCRIPTION
00	Terminal Invalid	Empty terminal, avoid false operation.
01	Run	Control the run and stop of the inverter, and also used to make up multiple control methods combining with other terminals.
02	FOR	Forward run.
03	REV	Reverse run.
04	STOP	Stop.
05	FOR/REV	Forward run, Reverse run shift switch.
06	JOG	Jog.
07	JOG FOR	Jog forward rotation.
08	JOG REV	Jog reverse rotation.
09	Emergency stop	The inverter would stop immediately when there was emergency.
10	RST	The inverter can be reset when the fault is cleared.
11	Reserved	
12	Overheat	Using this function to protect heat

		sink and motor from overheat.
13-16	Reserved	
17	High speed	These three speeds provide three different running patterns, and they are determined by the second, the third, and the forth frequency
18	Medium speed	
19	Low speed	
20	Multi-speed 1	These three speeds can provide seven different speed
21	Multi-speed 2	
22	Multi-speed 3	
23	ACCEL/DECEL time select 1	The acceleration and deceleration time can be selected by these terminals, altogether 4 patterns are available
24	ACCEL/DECEL time select 2	
25	UP	Every single press on these keys will make the inverter frequency go up or down for one unit, while if either key is kept pressing, the frequency value will swiftly go up and down continuously. If the power recovers after loss, the frequency set by UP/DOWN key will not exist any more
26	DOWN	
27	Counter	This terminal can receive pulse signal (<250Hz) and count the number.
28	Counter Reset	Pressing this key will clean up the former display data and reset the “CD00”, ready for the next counting.
29	Drafting	This function is special for chemical fiber instrument.
30	PID	This terminal is used to begin the PID function.

A、 Three-lines system connection using RUN. STOP .DCM

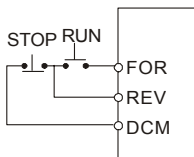

- 1) Using multi-function terminals FOR and REV
- 2) Parameter setting: CD033=1
CD050=01

CD051=04

B、 Using RUN.DCM.F/R to start,stop,forward and reverse run and reverse rotation.

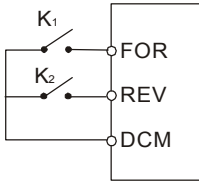

- 1) Using multi-function terminals FOR and REV.
- 2) Parameter setting: CD033=1
 CD050=01
 CD051=05
 K2 open for FOR run; K2 closed for REV run.

C、 Introduction of the acceleration or deceleration time select One and Two.

- 1. This function is only valid when CD076 is set for “0.1or 2” .When in disturbance and inner control multi-control speed method it is invalid.
- 2. Any two multi-function input terminals can make up 4 patterns of acceleration or deceleration time.
- 3. Take the SPH.SPM terminals as an example. When CD053 for SPH is set for “23”, and CD054 for SPM is set for “24”, the four acceleration or deceleration patterns are shown in the following table.

SPH terminal	SPM terminal	Results
OFF	OFF	The first acceleration or deceleration time
ON	OFF	The second acceleration or deceleration time
OFF	ON	The third acceleration or deceleration time
ON	ON	The fourth acceleration or deceleration time

D、 Introduction of high speed, medium speed and low speed terminals

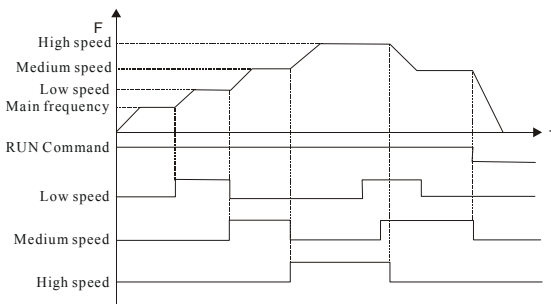

RUN	SPL terminal	SPM terminal	SPH terminal	Results
ON	OFF	OFF	OFF	Main speed and the run frequency are determined by CD000.
ON	ON	OFF	OFF	Low speed and the run frequency are determined by CD080.
ON	ON/OFF	ON	OFF	Medium speed and the run frequency are determined by CD081.
ON	ON/OFF	ON/OFF	ON	High speed and the run frequency are determined by CD082.

- Note:
- (1) This function is only valid when CD076 is set for“1”(i.e. in external control four speed)
 - (2) The frequency of low speed, medium speed and high speed are determined by the second,third,fourth frequencies.
 - (3) The acceleration or deceleration time is controlled by the acceleration or deceleration selection terminals.
 - (4) When multiple signals are received, it will have the priority from the high to the low.

E: UP/DOWN terminals

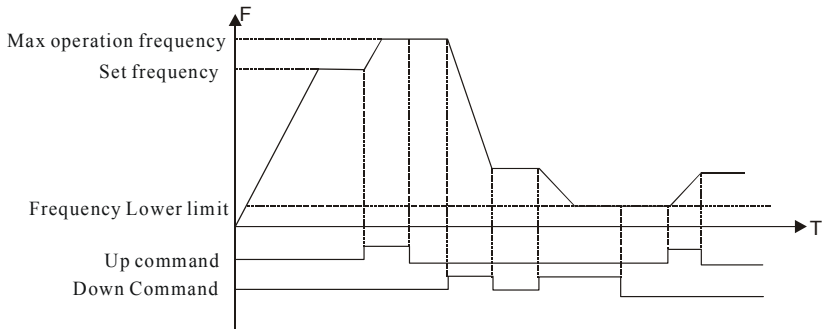

UP	DOWN	RESULTS
ON	OFF	Frequency up
OFF	ON	Frequency down
ON	ON	Neither up nor down

- Note:
- (1) UP/DOWN functions are only valid when the command method is set by digital operator(i.e. CD043 is set for “0”)
 - (2) If the UP terminal is closed, the inverter output frequency will gradually increase.
 - (3) If the DOWN terminals is closed, the inverter output frequency will gradually decrease.
 - (4) If the UP and DOWN terminals are closed at the same time, the frequency will not increase nor decrease.
 - (5) When the frequency reaches its highest operation frequency, it will not go up any more.
 - (6) When the frequency reaches its lowest operation frequency or its lower limit, it will not go down any further.
 - (7) If a momentary power loss occurs, the former frequency will not be remembered by the inverter and it will recover to its original CD000.
 - (8) Using UP/DOWN functions, the Δ ∇ keys on the digital operator are valid. After the data value is changed, users should press the “enter” key, and then the inverter will receive the new setting. And meanwhile this value will be stored into CD000.If power loss occurs; this data value will not be lost.
 - (9) Press the UP or DOWN terminals continuously, the frequency will swiftly go up or down.
 - (10)If data value is changed through “UP” and “DOWM” terminals ,by setting CD072,users can decide whether to forever modify and remember the new value or hot.(Refer to CD072)

F、Multi speed 1.2.3.

This function is only valid when CD076 is set for “2”.Related introduction refer to CD076.

G : Counting

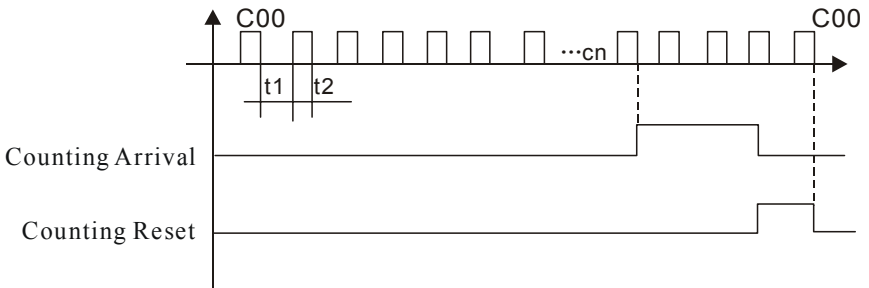

- Note: (1) Trigger signal width mustn't be narrow than 2msec ($t_1、t_2 \geq 2\text{msec}$);
- (2) When the counter arrives at its setting value, the corresponding multi-function output contact act.
- (3) The counter cannot do a new counting until it is reset.
- (4) When the counter arrives at its Max point 65535 it will not display the correct number with the number still going up.

CD056 Multi-function Output One(DRV terminal)Factory setting 01 **
CD057 Multi-function Output Two (UPF terminal) Factory setting 05
CD058 Multi-function Output Three - FA、FB、FC terminal Factory setting 02
CD059 Multi-function Output Four -KA、 KB terminal Factory setting 00
 Setting range: 00—32 Unit: 1

- | | |
|------------------|--|
| 00: no function | This is only for preventing false operation. |
| 01: running | The contact will act when the inverter is in running or receiving running command signals. |
| 02: fault signal | The contact will act when the inverter detected fault. |

03: zero speed	when the inverter output frequency is lower than its starting frequency.
04: DC brake indication	The contact will act when the inverter is in DC braking condition.
05: Up to set frequency	The contact will act when the output frequency has reached the set frequency.
06: Up to desired frequency ¹	The contact will act when the output frequency has reached the desired frequency (CD061).
07: Up to desired frequency ²	The contact will act when the output frequency has reached the desired frequency (CD062).
08: on accelerating	The contact will act when the inverter is accelerating.
09: on decelerating	The contact will act when the inverter is decelerating.
10: overload alarm	The contact will act when the inverter detected overload fault.
11: Motor overload alarm	The contact will act when the inverter detected motor overload fault.
12: Over torque alarm	The contact will act when the inverter detected over torque.
13: Under voltage alarm	The contact will act when the inverter detected under voltage fault.
14: Single stage end	The contact will act when the inverter has finished a single stage in its program running.
15: Whole process end	The contact will act when the inverter has finished the whole process in its program running.
16: Counting arrival	The contact will act when the internal counter has reached the setting value (CD064).
27: Drafting arrival	This contact will act when drafting is

- finished, when the inverter stops it will auto reset.
- 28: PID Lower alarm This contact will act when the PID feedback value is lower than the lower limit (CD156 setting).
 - 29: PID Upper limits alarm This contact will act when the PID feedback value is larger than the upper limit (CD155 setting).
 - 30: Fan run When the inverter is working in high temperature or in running, this contact will act.
 - 32: Braking resistor When the inverter is running and the DC voltage reaches its brake voltage, this contact will act.

CD060	Multi-function output 5	**
	Set range:0—7 Unit:1 Factory setting:1	

Function: Analog frequency output terminal, output 0-10V.It can be Joined together with CD071 for external monitoring if connected to a Frequency meter with a measuring range of 10V or below.

- 0: invalid 1: output frequency 2: output current (0—10V)
- 3: DC voltage (0—10V) 4: output voltage (0—10V)
- 5、 6、 7:invalid

CD061	Up to desired frequency 1 setting	**
CD062	Up to desired frequency 2 setting	
	Set range:0.00—400.00Hz Unit:0.01Hz Factory setting:0.00	
CD063	Up to frequency setting detection width	**
	Set range:0.00—10.00Hz Unit:0.01Hz Factory setting:0.50	

When the output frequency is in the range of up to frequency setting detection, the corresponding multi-function output will act. If it is not in the range, no contact will begin to act.

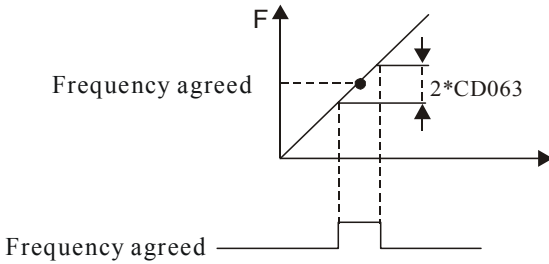

CD064 Counter set **
 Set range: 0—65500 Unit: 1 Factory setting: 0

The counter takes the multi-function external terminal as its contact Terminal. When the counting value reaches the set value of CD064, the corresponding multi-function output contact will act. The counter can go on for a new counting only after the former numerical value is cleared Up and the counter gets a reset. The trigger signal can be sent by Proximity switch and photoelectric switch, etc.

CD065 Analog input select
 Set range: 0—4 Unit: 1 Factory setting: 0

- 0: 0~10V 1: 0~5V 2: 0~20mA 3: 4~20mA
 4: both 0-10V and 4-20mA

This parameter setting can meet different analog input signals.
 When CD065=4, output frequency = $1/2(U/U_{max} + I/I_{max}) \times 50\text{Hz}$
 U: Analog Voltage U_{max} : Max Analog Voltage
 I: Analog Current I_{max} : ax Analog Current
 When the analog value is +10V and 20mA, the output frequency is 50Hz.

CD066 Lower analog frequency set point
 Set range: 0.00—400.00 Hz Unit: 0.01 Hz Factory setting: 0.00

CD067 Lower analog frequency bias direction
 Set range: 0—1 Unit: 1 Factory setting: 0

- 0: Positive direction

1: Negative direction

Bias direction means commands for FOR or REV run. Positive bias means FOR run; negative bias means REV run; Related setting, refer to CD070.

CD068 Higher analog frequency set point

Set range: 0.00—400.00 Hz Unit: 0.01Hz Factory setting: 50.00

CD069 Higher analog frequency bias direction

Set range: 0—1 Unit: 1 Factory setting: 0

0: Positive direction

1: Negative direction

Bias direction means commands for FOR or REV run. Positive bias means FOR run; negative bias means REV run; Related setting, refer to CD070.

CD070 Negative bias reverse select

Set range: 0—1 Unit: 1 Factory setting: 0

0: Negative bias reverse is invalid.

1: Negative bias reverse is valid.

This parameter group can set the measuring range and zero point of the external. Analog terminals and also can build any curve to control the motor running.

For example:

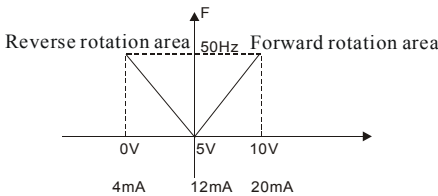

setting: CD066=50
 CD067=1
 CD068=50
 CD069=0
 CD070=1

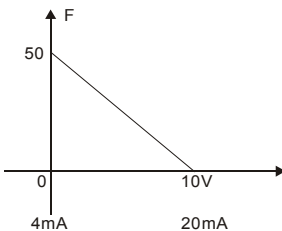

Setting: CD066=50
 CD067=0
 CD068=0
 CD069=0
 CD070=1

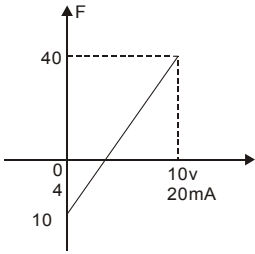

Setting: CD066=10
 CD067=1
 CD068=40
 CD069=0
 CD070=1

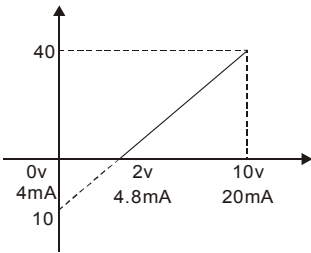

Setting: CD066=10
 CD067=1
 CD068=40
 CD069=0
 CD070=0

CD071 Analog output gain **
 Set range: 0.0—100.0% Unit:0.1% Factory setting: 100.0

This setting can adjust the output voltage of the six multi-function output terminals to adapt to the frequency meters with different measuring ranges and also it can help adjust the frequency meters according to this parameter.

CD072 UP/DOWN Function Select
 ** Set range:0—1 Unit:1
 Factory setting:1

0: Recorded 1: non-recorded

This setting can decide whether the new setting frequency modified by up/down function will be recorded or not. If CD072 is set for 0, then the new value will be recorded and when the inverter is re-started, the new data will be valid. If CD072 is set for 1, then any change of the frequency will be missed and the parameters shown on the display screen is their former settings after restarting the inverter.

CD073~CD075 Reserved

CD076 PLC mode select
 Set range: 0—4 Unit: 1 Factory setting: 0

- 0: normal running i.e. run by normal control method
- 1: external control four speed (related introduction refer to CD050-055)
- 2: external control multi speed

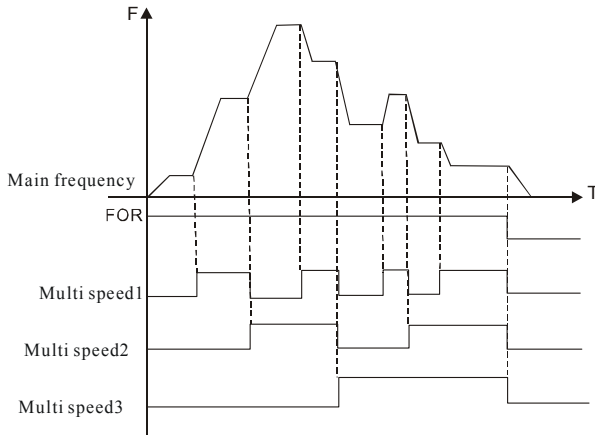

Multi-function Terminal			Result
Multi speed 1	Multi speed 2	Multi speed 3	
OFF	OFF	OFF	Main frequency and the frequency are determined by CD00 or external analog input.
ON	OFF	OFF	Speed 1 and the frequency are determined by CD080.
OFF	ON	OFF	Speed 2 and the frequency are determined by CD081.
ON	ON	OFF	Speed 3 and the frequency are determined by CD082.
OFF	OFF	ON	Speed 4 and the frequency are determined by CD083.
ON	OFF	ON	Speed 5 and the frequency are determined by CD084.

OFF	ON	ON	Speed 6 and the frequency are determined by CD085.
ON	ON	ON	Speed 7 and the frequency are determined by CD086.

- Note: ① Only when the multi-function input terminals are set to be multi speed 1,2,3 and CD076 is set for “2”. The function of external control eight speed running method can be realized.
- ② Seven speeds can be made up by different combinations of Multi speed 1,2,3, plus the main frequency. Thus eight speeds are available.
- ③ The frequencies of speed1—speed7 are determined by CD080—CD086.
- ④ Every single acceleration or deceleration time is determined by external multi-function terminals.
- ⑤ Every single program running direction is determined by external multi-function terminals.
- ⑥ The main frequency is decided by two methods. One is set by CD000; the other is set by external analog input signal. When CD034 is set for 1, the main frequency is set by the external analog input signal. Rated setting, refer to CD000, CD034, CD080—094.

3: Disturbance(the function of cross traverse)

This parameter is set particularly for the realization of cross traverse in the chemical fibre, printing and dyeing industry. In running, any other command will not be accepted except for “stop, external fault and emergency stop”.

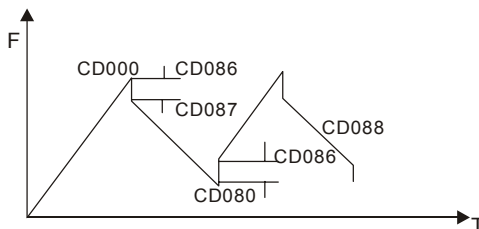

- Note:
- ① Every break frequency is determined by CD000 and CD080.
 - ② Skip frequency is determined by CD086.
 - ③ Running time is controlled by timer CD087,CD088.
 - ④ Related setting: refer to CD000,CD080—088.

4: Inner control multi speed

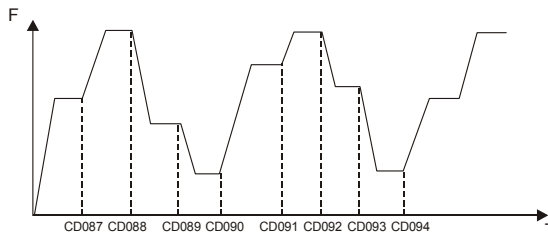

- Note:
- ① Main speed and seven-step speed make up eight-step speed.
 - ② Every single acceleration or deceleration time is set by PLC acceleration or deceleration time (CD079).Related introduction refer to CD079.
 - ③ Running time is controlled by timer CD087-CD094.The timer should be set for “0” for idle control step.
 - ④ The running direction of every single step is set by CD078.
 - ⑤ When in inner control multi speed running, the running time and direction are both set by inner parameters.The external command for time switch or FOR/REV rotation switch is invalid.

5. Drafting

This setting is especially for the realization of constant speed for giving and receiving the rolled string.

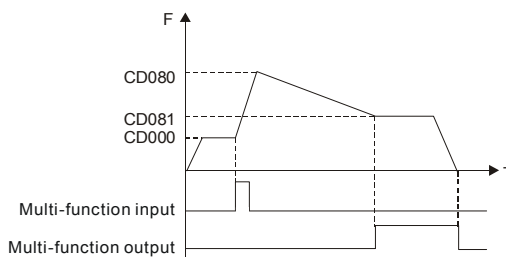

- Note:①Drafting is energized by the external multi-function terminal.
- ②When executing the drafting is running action, the running time is: $T=CD087 \times 10$
- ③When drafting is finished, the inverter at a constant speed(CD081),and at the same time, the corresponding multi-function output contact is energized until a “stop” command is received.

CD077 Auto PLC Select

Set range: 0—3

Unit: 1

Factory setting: 0

0: stop after running one circle

1: circulating running

2: stop after auto running one circle (with stop interval)

3: auto circulating running (with stop interval).

This parameter setting is valid only when CD076 is set for “4”.

Related introduction refer to CD000, CD076, CD078~CD094,

Note: 0: stop after running one circle the inverter will start to execute the circulating running command at its inner parameter set value and stop after running one circle. Only when the inverter receives a new running command, will it start to run again.

1. Circulating running

The inverter will start to have a circulating running in its set order at its inner parameter set value of step frequency and running time when the inverter receives the running command. Any other command will not be accepted in the circulating running, except for “stop”, “external fault”, and “emergency stopped”.

2: Stop after auto running one circle(with “stop” interval)

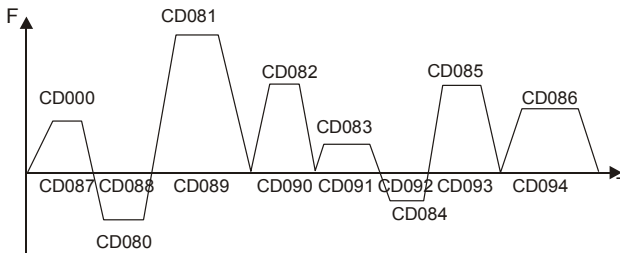

Note:

- 1) When the auto running command is received, the inverter begin to run at its parameter set value .When every stage changes, the inverter will first stop and then restart again. The inverter will automatically stop after running for one circle. Only when a new running command is received, will the inverter begin to run again.
- 2) The frequency for different steps is set by CD000, CD080-CD086.
- 3) The running time for different steps is set by CD087-CD094.
- 4) The running direction is set by CD078.

3: Auto circulating running(with “stop” interval)

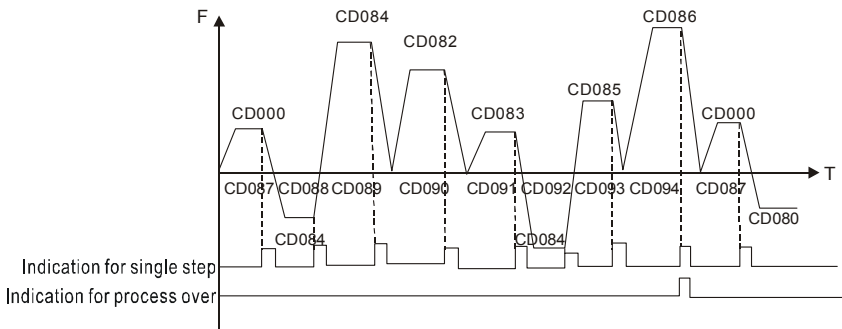

Note: 1) When the inverter receives the auto running command, it begin to run in its parameter set order. When every stage changes, it will first stop and then restart, and go on running till the auto running command turns to “OFF”.

- 2) When a single step is finished, the corresponding multi-function output contact will act.
- 3) When a process is finished, the corresponding multi-function output contact will act.
- 4) Output pulse width is 20ms.

CD078 PLC running direction

Set range: 0—255 Unit: 1 Factory setting: 0

This parameter setting is only valid, when CD076 is set for “4”.

This parameter will determine the running directions of different frequency steps of CD080~CD086.CD00 in PLC running.

The running direction is set by the binary 8 BIT method, and then be changed into decimal system to set this parameter. See the following diagram.

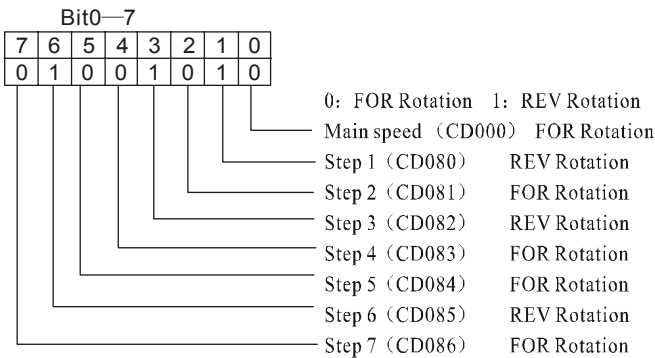

Parameter value 01001010 to be changed into decimal system, i.e.

$$1 \times 2^6 + 1 \times 2^3 + 1 \times 2^1 = 64 + 8 + 2 = 74$$

So the parameter of CD078 should be 74.

CD079 PLC Accel./Decel.time

Set range: 0~65535 Unit: 1 Factory setting: 0

This parameter setting valid only when CD076 is set for “4”.

This parameter setting determines the acceleration or deceleration time of the inner control multi-step speed and every signal step speed. It is set as follows:

1 Binary 2BIT method

BIT	BIT	Acceleration or Deceleration Time
1	0	
0	0	The first acceleration or deceleration time CD012,CD013
0	1	The second acceleration or deceleration time CD014,CD015
1	0	The third acceleration or deceleration time CD016,CD017
1	1	The fourth acceleration or deceleration time CD018,CD019

2 Binary 16BIT method

Speed8		Speed7		Speed6		Speed5		Speed4		Speed3		Speed2		Speed1	
t8		t7		t6		t5		t4		t3		t2		t1	
0	0	0	0	0	0	0	0	0	1	1	0	0	0	1	1

t1 choose the fourth acceleration or deceleration time

t2 choose the first acceleration or deceleration time

t3 choose the third acceleration or deceleration time Set parameter

t4 choose the second acceleration or deceleration time $1 \times 2^0 + 1 \times 2^1 + 1 \times 2^5 + 1 \times 2^6 = 99$

t5 choose the first acceleration or deceleration time So CD079 should be set "99"

t6 choose the first acceleration or deceleration time

t7 choose the first acceleration or deceleration time

t8 choose the first acceleration or deceleration time

CD080	The second frequency setting	Factory setting	15**
CD081	The third frequency setting	Factory setting	20
CD082	The fourth frequency setting	Factory setting	25
CD083	The fifth frequency setting	Factory setting	30
CD084	The sixth frequency setting	Factory setting	35
CD085	The seventh frequency setting	Factory setting	40
CD086	The eighth frequency setting	Factory setting	0.5
	Set range: 0.00—400.00 Hz	Unit: 0.01 Hz	

This setting combining the multi-function input terminal can form external control 4-step speed, external control multi-step speed, and inner control multi-step speed.

Related setting: refer to CD076, CD087~CD094.

CD087	Timer one	Factory setting	10.0**
CD088	Timer two	Factory setting	10.0
CD089	Timer three	Factory setting	0.0
CD090	Timer four	Factory setting	0.0
CD091	Timer five	Factory setting	0.0
CD092	Timer six	Factory setting	0.0
CD093	Timer seven	Factory setting	0.0
CD094	Timer eight	Factory setting	0.0
Set range: 0.0—6500.0S		Unit: 0.1S	

This setting is to determine the running time of executing drafting function and inner multi-step speed running.

Related setting: refer to CD076, CD080~CD088.

CD095—CD119	Reserved
--------------------	-----------------

CD120	Stall prevention select		
	Set range: 0—1	Unit: 1	Factory setting: 1

0: The function of stall prevention is invalid.

1: The function is valid.

When the inverter is in decelerating, because of the effect of load, the motor will produce a return energy to the inverter and cause the DC side voltage of the inverter increase. So when the function of over voltage stall prevention is set valid and the DC voltage of the inverter becomes too high, the inverter will stop decelerating till the DC bus voltage decreases to allowed value, then the inverter will go on to execute deceleration and of course the deceleration time will be longer.

CD121	Stall prevention level during acceleration		
	Set range: 0—200%	Unit: 1%	Factory setting: 150

When the inverter is in accelerating, because of over load or too short acceleration time, the output current of the inverter will go up

quickly and exceed the rated value level. When this happens, the inverter will stop accelerating, until the current returns under its rated value, will the inverter go on to accelerate.

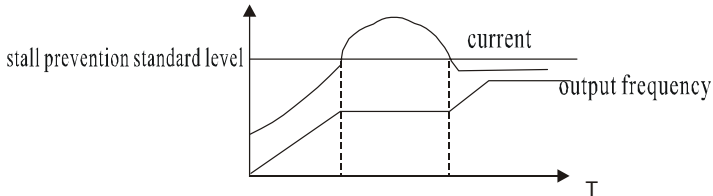

100% current is the motor rated current. If this parameter is set for "0", stall prevention function is invalid.

CD122 Stall prevention level during running

Set range: 0—200% Unit: 1% Factory setting:

0

When the inverter is in constant speed running, because of the change of load and some other reasons, the current will go up. When the current exceeds its rated value, the inverter will lower the output frequency. When the output current returns to its normal range the inverter will accelerate to its set frequency again.

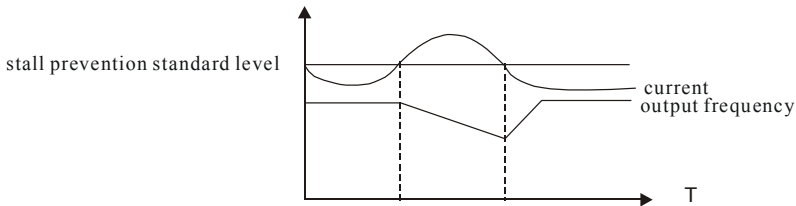

100% current is the motor rated current.

If this parameter is set for "0", stall prevention function is invalid.

CD123 Stall prevention level during decelerating

Set range: 0—200% Unit: 1 Factory setting: 150

Related introduction refer to CD120

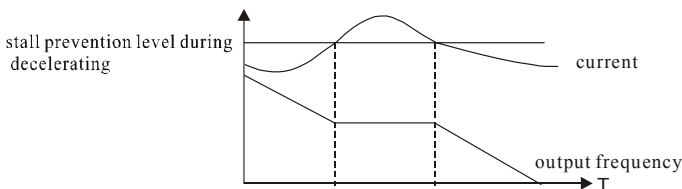

100% current is the motor rated current.

CD124 Reserved

CD125 Over torque detection level

Set range: 0—200% Unit: 1% Factory setting:

0

When the output current exceeds the over torque detection level and also exceeds half of the over torque detection time (factory setting: 1.0s), the over torque detection will begin to work, and the corresponding multi-function contact will act. When it exceeds the set time value, the inverter will turn into self-protection. But when this parameter is set for “0”, the over torque detection will be invalid.

CD126 Over torque detection time

Set range: 0.1—20.0s Unit: 0.1s Factory setting: 1.0

When the inverter detects that the output current has exceeded the rated current, the inverter begins to calculate the over torque time. When the over torque time has exceeded half of the over torque detection time, the corresponding multi-function output contact will act, the over torque warning will be produced, while the inverter will continue running. When the over torque time has exceeded the set detection time (set by CD126), the inverter will turn into self-protection, display the fault signal and stop output.

Related introduction refer to CD125.

CD127—CD129 Reserved

CD130 Rated voltage

Unit: 0.1V Factory setting:*

Set according to the rated voltage shown on the nameplate of the motor. The factory setting for 230-v class inverters is 220, for 440-v class inverters is 380.

CD131 Rated current

Unit: 0.1A

Factory setting:*

Set according to the rated current shown on the nameplate of the motor. With this parameter users can limit the inverter output current, prevent over current, and protect the motor. If the motor current exceeds this set value, the inverters will turn into self-protection.

CD132 Motor Poles

Set range: 02—10

Unit: 1

Factory setting: 04

This parameter should be set according to the motor nameplate.

CD133 Rated rotational speed

Set range: 0—9999

Unit: 1r/min

Factory setting: 1440

This parameter should be set according to the actual motor rotation speed. The display value is the same as this parameter. It can be used as a monitoring parameter which brings convenience for users to monitor the running state. This parameter set value is corresponding to the rotational speed at 50Hz.

CD134~CD139 Reserved

CD140 DC braking level

Set range: 0.0—20.0%

Unit: 0.1%

Factory setting: 2.0

This setting determines the DC brake voltage of the motor when starting or stopping. Adjustments of this parameter can result in different brake voltage values. When adjustments are being done, users must increase the parameter value slowly until it gets enough brake torque.

100% voltage is the output voltage at Max frequency.

CD141 DC braking time at starting

Set range: 0.0—25.0S Unit: 0.1S Factory setting: 0.0

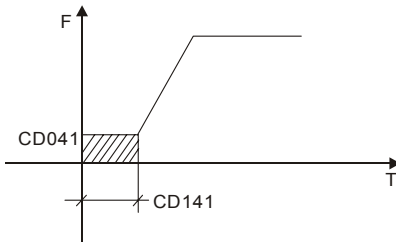

This setting determines the DC braking lasting time during DC brake at starting.

If it is set for “0” it means DC brake is invalid.

The DC brake at starting is usually used in the cases in which the load is movable in the “stop” state.

Such as cooling fan and some other machines. Because of the load, the motor is always in a free running state, with an uncertain running direction.

Users can first start the DC brake before starting the inverter to prevent the inverter from tripping.

This setting is valid only when CD131 is set for “0”.Related introduction refer to CD031,CD140.

CD142 DC braking time at stopping

Set range: 0.0—25.0 Unit: 0.1S Factory setting: 0.0

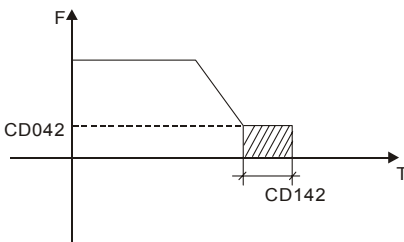

Note:This setting determines the DC braking time at stopping when it is not set for “0”.The DC brake at stopping is usually used in high position shutdown or for location control. This setting is valid only when CD032 is set for “0”.Related introduction refer to CD032, CD042, CD140.

CD143 Speed search time

Set range: 0.1—20.0S Unit: 0.1S Factory setting: 2.0

This parameter is set as speed search time when the inverter restarts by the speed search method after clearing the external faults or a momentary power loss. For the starting and stopping of some large inertia load, because of its large inertia, if users restart the machine after its complete stop, it will waste much time. But using the speed search function, things are different. You needn't wait for the machine's fully stop, the inverter will make a frequency tracking from high to low at its set frequency. After tracking the inverter will continue to accelerate to reach the set frequency.

CD144 Speed search current level

Set range: 0—200% Unit: 1% Factory setting: 150

When the inverter is making a speed search, if the output current is higher than this standard level, the inverter will decrease the frequency to make the current return to its normal range and then execute the command of speed search again.

CD145 Restarting select after a momentary power loss

Set range: 0—1 Unit: 1 Factory setting: 0

- 0: invalid no auto restarting after a momentary power loss
- 1: restart by speed search Related introduction refer to CD143

CD146 Momentary power loss ride through time

Set range: 0.1—5.0S Unit: 0.1S Factory setting: 0.5

This setting determines the longest time allowable for momentary power loss. If it exceeds the allowable time; the inverter will still be in a stop state after the power recovery occurs. If users want to restart the inverter, you need to follow the normal starting steps again.

CD147 Number of auto restarting attempt

Set range: 00—10 Unit: 1 Factory setting: 00

When meeting abnormal situations such as over current, over

voltage, etc, the inverter will have an auto reset and restart itself. If the starting method is set as normal starting, the inverter will start in the normal method. If the starting method is set as speed search starting, the inverter will start in the speed search method. After restarting, if meeting no new abnormal situation after 60 second, the parameter will return to its set value again. If meeting new abnormal situations again and again, and reaching the Number of auto restarting attempt, the inverter will stop output. Only after reset can the inverter restart again. If CD147 is set for “0”, the inverter will not have auto reset and restart function in abnormal situations.

CD148 Auto voltage regulation

Set range: 0—1

Factory setting: 1

0: invalid

1: valid

Under the situation of unstable power supply, if the voltage is too high and the motor is running at a higher voltage than it’s rated, this will cause the motor temperature to increase, the insulation to be destroyed, and output torque to be unstable. The auto voltage regulation function can keep the output voltage within the rated motor voltage.

When this function is set for “0” there will be fluctuation of the output voltage.

CD149 Auto energy saving

Set range: 0—20%

Unit: 1%

Factory setting: 0

If this parameter is set for “0”, the energy saving function is invalid. In auto energy saving, it will run at its full voltage when accelerating or decelerating; when in constant running it will run at the best voltage value which is auto calculated by the load power and thus reach the purpose of energy saving.

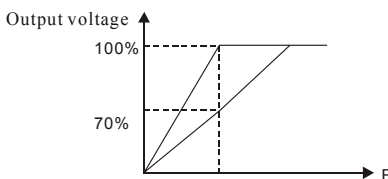

The Max energy saving rate can reach 30%. But for those have frequent load changes or are almost full loaded, this function is not suitable.

CD150 Proportional Constant: P **
Set range: 0.0~1000.0% Unit: 0.1% Factory setting: 100%

This setting determines the error value gain. If I=0, D=0, it is only for proportion control.

CD151 Integral Time: I **
Set range: 0.1~3600.0s Unit: 0.1s Factory setting: 5.0s

This setting determines the reaction speed for PID.

The larger the I value is the slower the reaction speed is. But if the integral time value is set too small, it will cause vibration.

CD152 Differential Time: D **
Set range: 0.01~10.00s Unit: 0.01s Factory setting: 0

This setting determines the depression operation of PID.

The larger the D value is, the more obvious the depression operation is. When D is set for "0", it means this function invalid.

CD153 Target Value **
Set range: 0~100.0% Unit: 1% Factory setting: *

The target value can be set through external voltage signal or the digital operator. 100% target value is corresponding to the frequency when the analog voltage is 10V.

PID closed-loop control is usually used in the control of processed of no fast physical quantity changes, such as pressure control, temperature control, etc. The feedback signal is usually taken from temperature, or pressure translator etc. When under PID control, the feedback signal input path is the analog current signal 4-20mA.

PID closed-loop control is valid only when the multi-function inputs PID are open.

PID Control Diagram:

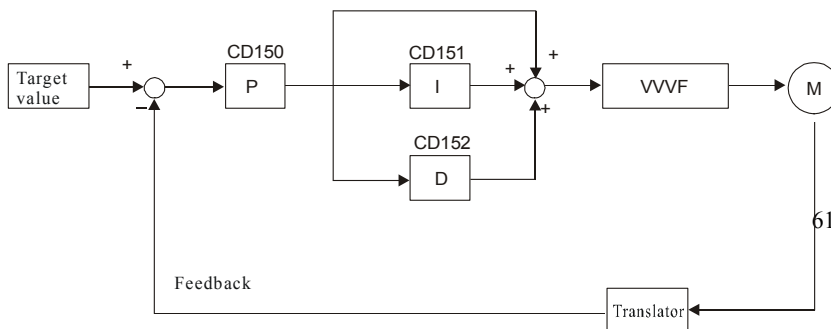

General operating methods of PID control:

- (1) Choose the correct translator (with output specification of standard current signal 4-20mA)
- (2) Set the right target value.
- (3) If the output doesn't have oscillation, increase the proportional constant (P);
- (4) If the output doesn't have oscillation, decrease the integral time (T_i);
- (5) If the output doesn't have oscillation, increase the differential time (T_d);
- (6) Application Examples as follows:

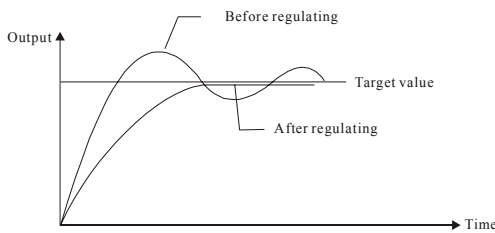

1. Decrease the Over Output
 - a. decrease the differential time (D)
 - b. increase the integral time (I)

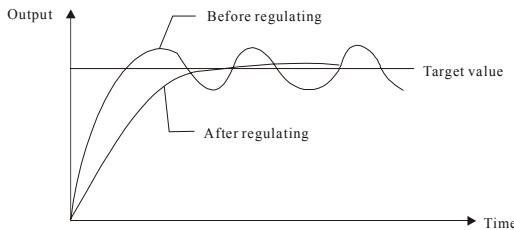

2. Decrease the oscillation
 - a. decrease the differential time (D) or set it for "0"
 - b. decrease the proportional constant

(P)

CD154	PID Target Value Source	**
Set range: 0~1	Unit: 1	Factory setting: 0

The target value can be set through the digital operator and the external analog signals. The external analog signal is given by 0-10V signal or Variable Resistor.

When CD154=0, the target value of PID is set by CD153.

When CD154=1, the target value of PID is set by external analog signal 0-10V (corresponding 0-100%), the setting of CD153 is invalid.

CD155 PID Upper Limit	**
Set range: 0~100 %	Factory setting: 100%

When the PID feedback value is higher than the setting of CD155, the corresponding multi-function output contact will be energized. While the machine will not stop working.

CD156 PID Lower Limit	**
Set range: 0~100%	Factory setting: 0%

When the PID feedback value is lower than the setting for CD156, the corresponding multi-function output contact will be energized. While the machine will not stop working.

CD157~CD159 Reserved

CD160 Communication identified no		
Set range: 00~250	NO.	Factory setting: 00

When the inverter is set to be RS-485 Communication control. The inverter will be set an individual identified No.

00: no communication function

01~250: inverter individual identified No.

CD161 Baud rate of communication		
Set range: 0~3	Unit: 1	Factory setting: 1

0: 4800 bits/second

1: 9600 bits/second

2: 19200 bits/second

3: 38400 bits/second

CD162 Communication Data Method		
Set range: 0~5	Unit: 1	Factory setting: 0

0: 8N1 For ASC II

1: 8E1 For ASC II

2: 8O1 For ASC II

3: 8N1 For RTU

4: 8E1 For RTU

5: 8O1 For RTU

HC1 MODBUS communication agreement

When we use inverter with RS485 communication interface each of them must be set an individual address Thus the computer can use this address to control the inverter.

1: communication agreement has two modes

- 1) RTU mode (Remote Terminal Unit)
 - 2) ASC II mode(America Standard Code for information interchange)
- Information of code.

RTU mode:

Each of 8-BIT data is composed of two 4-BIT data, for example: 64H
ASC II mode:

Each of 8-BIT data is composed of two ASC II byte, for example:
64H(hexadecimal)is composed of ASC II byte“64”,included“6”(36H)
and “4”(34H).

Character symbol	0	1	2	3	4	5	6	7
ASCII	30H	31H	32H	33H	34H	35H	36H	37H

2: Communication data mode

Character symbol	8	9	A	B	C	D	E	F
ASCII	38H	39H	41H	42H	43H	44H	45H	46H

3: Communication data format

3.1 ASC II mode

Communication data format

STX “.” (3AH)	ADDR	FUNC	LEN	DATE _(n-1) ···DARA ₀	LRC	END CR (0DH) LF (0AH)
---------------------	------	------	-----	--	-----	-----------------------------

- 1) STX: start data “.”(3AH)
- 2)ADDR communication address,8-BIT data is composed of two ASC II byte.
00: broadcast for all inverter
01— 250: the address of the inverter.
- 3) FUNC:function code,8-BIT data is composed of two ASC II byte.
01: read the data of function code
02: write the data of function code
03: control command

- 04: read status data
- 05: write inverter frequency data
- 06: keep
- 07: keep
- 08: loop test

a. Read function code data

format:

ADDR 01 LEN FUNC DATA

ADDR=0 means no answer

ADDR=1-250 Means having answer from inverter with this address

When the inverter reply normally the format is as below.

ADDR 01 LEN FUNC DATA

If DATA is one word, the LEN=3

If DATA is one byte, the LEN=2

When the inverter has not gotten this function code. Or the reply is ineffective, the format is as below

ADDR 81H 01FUNC.

b. Write function code data

format: 02 LEN

ADDR FUNC DATA

ADDR=0 for broadcast, it would write to all inverters, but no reply

ADDR=1-250 could set data and have answer from the inverter with this address.

When the inverter has not gotten this function code. Or the reply is ineffective, the format is as below

ADDR 82H 01 FUNC.

c. Control command

format: LEN

ADDR 03 CNTR

ADDR=0 for broadcast, it would write to all inverters, but no reply

ADDR=1-250 could set data and have answer from the inverter with this address.

CNTR format

7	6	5	4	3	2	1	0
Jog REV	Jog FOR	Jog	FOR/REN	STOP	REV	FOR	Run

When inverter reply normal, format as follows

ADDR 03H 01 CNST

CNST format

7	6	5	4	3	2	1	0
Start	DC Brake	FOR/REV	joggin	running	FOR/REV	Jog	Run
By speed search			g				

When the command is in correct or the reply is ineffective, the format is as below ADDR 83H 01 CNST.

d.Read status data

format:

ADDR 04 01 CFG

ADDR=0 for broadcast, it would write to all inverters but no reply.

ADDR=1-250 would have reply from inverter with this address

CFG=0 reply all data

CFG=1-8 reply single data

CFG data is defined as following

- 1:Set F Set frequency
- 2: Out F Output frequency
- 3: Out A Output current
- 4: Rot T Rotational speed
- 5: DCV DC voltage
- 6:ACV Output AC voltage
- 7:Cont Count
- 8:Tmp Temperature

4) LEN: data length

it means the length of $D_{(n-1)} - D_{(0)}$

If the data is one word the LEN is 3

If the data is one byte the LEN is 2

5) DATA: data content

each of 8-BIT data is composed of two ASC II byte, it have fifty ASC II at most.

6) LRC: longitudinal redundancy check

The method to get LRC is that add all the data from ADDR to the last byte of DATA, if the result is more than 256, then the result subtract 256 until the result is less than 256, then 100H subtract the result get LRC.

7) For example: write 30.00Hz to inverter with the address 01.

STX	ADDR	FUNC	LEN	DATA	LRC	END
“.”	“0” “1”	“0” “2”	“0” “3”	“0” “0” “0” “B” “B” “8”	“3” “7”	“CR” “LF”
3AH	30H31H	30H32H	30H33H	30H30H30H42H42H38H	33H37H	0DH0AH

Calculate LRC:

$$01H+02H+03H+00H+0BH+B8H=C9H,$$

$$100H-C9H=37H$$

so the sent data is following

3AH 30H 31H 30H 32H 30H 33H 30H 30H 30H 42H 42H 38H
33H 37H 0DH 0AH

3.2 RTU mode

QUIET	ADDR	FUNC	LEN	D _(n-1) ~D ₍₀₎	CRC	QUIET
>50ms						>50ms

- 1) QUIET: the time of no data is more than 50ms
- 2) ADDR: communication address, 8 bit data.
- 3) FUNC: function code, 8-BIT data, refer to 3.1-3
- 4) LEN: data length, the length of D_(n-1) – D₍₀₎
- 5) DATA: data content, n*8-BIT data
- 6) CRC: cyclical redundancy check

The CRC calculation method is shown as following.

- 1: make a register and set value 0FFFFH (call CRC register)
- 2: done first byte of data Exclusive OR with low byte of CRC register
- 3: done right shift with CRC register and fill zero to the leftist BIT, then check low BIT of CRC register
- 4: if the low BIT is zero, then repeat step3, else CRC register do Exclusive OR with 0A001H
- 5: repeat step 3 and 4, until CRC register does right shift 8 times
- 6: repeat step 2 to 5 for the next byte of data, until the process for all data is complete.

The final value of CRC, register is CRC when send CRC data, Low byte and high must exchange each other; it is to say the low byte would

be sent first.

7: Example:

Write 30.00Hz to inverter with address 01
command data

ADDR	FUNC	LEN	DATA	CRC
01H	02H	03H	00H 0BH B8H	7FH 0CH

Send data 01H 02H 03H 00H 0BH B8H 7FH 0CH

8: Example 2:

the following is that get CRC value with C language.

The function has two parameters

Unsigned char data ← the point of data buffer

Unsigned char length ← number of data buffer

This function will send back the CRC value with unsigned integer format.

```

unsigned int crc_chk(unsigned char data unsigned char length) {
    int j;
    unsigned int reg_crc=0xffff;
    while(length——) {
        reg_crc^=*data++;
        for(j=0;j<8;j++= {
            if(reg_crc&0x01) { /*LSB(b0)=1*/
                reg_crc=(reg_crc>>1)^0xa001;
            } else {
                reg_crc=reg_crc>>1;
            }
        }
    }
    return reg_crc;
}

```

CD163~CD167 Reserved

CD168 Display mode select

Set range: 0—15

Unit: 1

Factory setting: 0

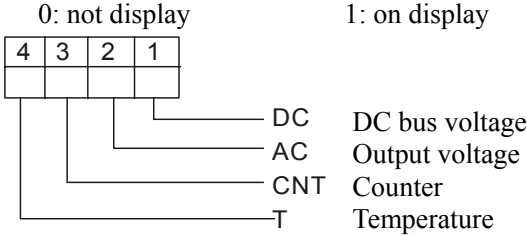

This parameter setting can be used to choose different items to be displayed, such as the counting, DC voltage, AC voltage and inverter temperature, etc. It's easy for users to monitor running status and the items are displayed in the order by switching.

Set method: binary 4 BIT first, then be changed into decimal system. Related introduction refer to CD078.

CD169 Voltage class of the inverter

Unit: 1V

Factory setting: *

Different factory settings according to different models. Only for checking and verifying.

CD170 Rated current of the inverter

Factory setting: *

Unit: 1A

Different settings according to different models. It can not be changed.

CD171 Software edition

Factory setting: *

Only for checking and verifying.

CD172 Fault Record 1

Factory setting: _____

CD173 Fault Record 2

Factory setting: _____

CD174 Fault Record 3

Factory setting: _____

CD175 Fault Record 4

Factory setting: _____

Note: _____ means no fault record.

CD176 Fault cleared

**

Set range: 00—10

Unit: 1

Factory setting: 00

Only "01" means fault cleared. Others are not valid.

CD177 Reserved

CD178 Frequency standard of the inverter

Set range:0—1

Unit:1

Factory setting: *

0: 50Hz

1: 60Hz This parameter is a factor setting only for checking and verifying.

CD179 Manufacture date

Factory setting: *

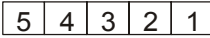

This parameter is a factory setting, only for checking and verifying.

CD180 Manufacture sequence number

Factory setting: *

This parameter is a factory setting, only for checking and verifying.

CD181~CD250 Reserved

Note: * means: this setting has several choices and it should be set according to actual situation or condition.

** Means: this setting can be changed during run mode.

10. Maintenance, Inspection, Error Information and Troubleshooting.

The inverter will be efficient and its service life function efficiently and its normal operation lifetime will be longer if it has been maintained and inspected maintenance and inspection periodically.

10.1. Precautions about maintenance and inspection:

- During inspection, turn off AC power supply first.
- When perform maintenance and inspection make sure that the CHARGE lamp in the power circuit board has gone off.
- During inspection, do not change the wiring, or remove connectors, it will cause damage to the inverter.
- Do not leave any metal objects in the inverter after the service, or it will result in short circuit.
- Keep the inverter clean, and dry, avoid dust, oil mist and moisture.

10.2. Periodic maintenance and inspection items

- Whether the power supply voltage conforms to the rated voltage of the inverter. (Pay special attention that whether there is any damage on the power supply wires and the motor.)
- Whether the wiring terminals and the connectors are tight.
- Whether there is dust, iron filings or corrosive fluid in the inverter.
- Never measure the inverter insulation impedance.
- Examine the output voltage, output current and output frequency.
- Whether the temperature of the inverter working space is between -5°C and 40°C .
- Whether the humidity is kept below 90 % (no condensation).
- Whether the motor is vibrating or making unusual noises in running.
- Periodic cleaning of the vent holes should be done.

10.3. Fault indication and troubleshooting

Fault Code	Content	Solution
E.OC.A	Over current during acceleration	<ol style="list-style-type: none"> 1: check whether the motor has got short circuit and the insulation of the output wires is well. 2: extend the accelerating time. 3: select a larger inverter. 4: lower the torque set value
E.OC.n	Over current during constant speed	<ol style="list-style-type: none"> 1: check whether the motor has got short circuit, whether the insulation of the output wires is well. 2: check whether the motor is rotating with some external jamming force, whether there is a sudden change of mechanical load. 3: select a larger inverter 4: whether there is a sudden change of network voltage.
E.OC.d E.OC.S	Over current during deceleration	<ol style="list-style-type: none"> 1: whether the insulation of the output wires is well, whether the motor has got short circuit. 2: extend the decelerating time. 3: select a larger inverter. 4: lower the DC braking voltage.
E.GF.S E.GF.a E.GF.n E.GF.d	Short circuit to earth	<ol style="list-style-type: none"> 1: check whether the motor has got any short circuit. 2: check whether the insulation of the output wires is well. 3: notify your supplier to check.
E.ou.S E.ou.a E.ou.n E.ou.d	<p>Over voltage during stopping</p> <p>Over voltage during acceleration</p> <p>Over voltage during constant speed</p> <p>Over voltage during deceleration</p>	<ol style="list-style-type: none"> 1: extend the decelerating time or add a braking resistor. 2: correct the input voltage of the network source; check whether there is a sudden change in voltage.

Fault code	Content	Solution
E.Fb.S E.Fb.n E.Fb.a E.Fb.d	Fuse break	Notify your supplier to check.
E.Lu.s E.Lu.A E.Lu.n E.Lu.d	Low voltage	1: check whether the input voltage in normal. 2: check whether there is sudden change of load. 3: check whether there is any absent phase.
E.OH.S E.OH.A E.OH.n E.OH.d	Inverter overheating	1: check whether the fan works well, whether there is any foreign matter stuck in the heat sink. 2: check whether the environment temperature is suitable for normal working. 3: check whether there is enough ventilation space and good air convection.
E.OL.A E.OL.n E.OL.d	Inverter overload	1: select a larger inverter. 2: check whether there is any jamming in the mechanical load. 3: select optimum V/F pattern.
E.OA.A E.OA.n E.OA.d	Motor overload	1: check whether there is a sudden change of mechanical load. 2: select a larger inverter. 3: check whether the insulation of the motor is well. 4: check whether there is any big unsteady voltage wave. 5: check whether there is any absent phase.
E.OT.A E.OT.n E.OT.d	Over torque	1: check whether there is any fluctuation of mechanical load. 2: select a larger inverter.
E.bS.A E.bS.n E.bS.d E.bS.S	No feedback of the auxiliary coil of the electromagnetic contactor in the inverter	Notify your supplier to check.
E.bT.A E.bT.n E.bT.d	Braking transistor in fault	Notify your supplier to check.

Fault code	Content	Solution
E.EC.S E.EC.n E.EC.d E.EC.A	CPU fault	Notify your supplier to check.
E.EE.S E.EE.n E.EE.d	E ² Prom fault	Notify your supplier to check

Er	External Interference	Isolate from the interference source
ES	Emergency Stop	In Emergency Stop Status
20	4-20mA wire broken	Join the broken wires
Pr	Setting error	Correct the setting
DCb	DC braking	In DC braking status

Note:①Fault Code Description:

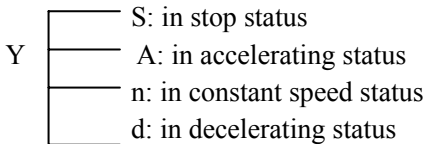
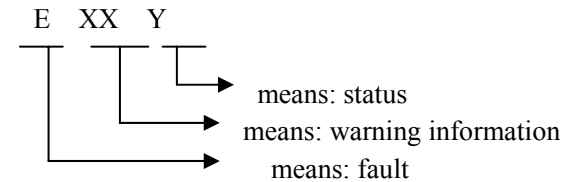

② Code Comparison:

A	B	C	D	E	F	G	H	O	S	N	L	T	P	R	U	2
<i>A</i>	<i>b</i>	<i>C</i>	<i>d</i>	<i>E</i>	<i>F</i>	<i>G</i>	<i>H</i>	<i>O</i>	<i>S</i>	<i>n</i>	<i>L</i>	<i>T</i>	<i>P</i>	<i>r</i>	<i>u</i>	<i>2</i>

10.4 Trouble shooting

(1) If the motor does not operate:

- 1) The operation method setting is wrong.
- 2) The frequency reference is too low or isn't given.
- 3) Multi-function input terminals function setting error.
- 4) Peripheral wiring is wrong, for example, the 2-wire sequence, 3-wire sequence or related setting is wrong.
- 5) The inverter is in the fault protection status.
- 6) Motor fault.

- 7) Inverter fault.
- (2) The parameter can not be set:
 - 1) Unlock the parameter lock function (CD010).
 - 2) The inverter is in running.
 - 3) Abnormal connection of the connectors, abnormal communication of the digital operator. Cut off the power supply, take down the digital operator and fit it again.
- (3) The motor only rotates in FOR direction.

“Reverse run prohibited” is selected.
- (4) If the direction of the motor rotation is reversed.

The motor output wiring is faulty. Switching two wires among U.V.W will settle the problem.
- (5) If motor deceleration is too long
 - 1) The deceleration time setting is too long.
 - 2) Add braking resistor.
 - 3) Add DC brake.
- (6) If the motor overheats.
 - 1) The load is too big. Consider increasing the motor capacity.
 - 2) The ambient temperature is too high. The motor will burn out if it is run continuously at the rated torque in an environment in which the maximum ambient operating temperature is exceeded. Lower the motor’s ambient operating temperature.
 - 3) The withstand voltage between the motor phases is insufficient.

When the motor is connected to the inverter output, a surge is generated because of the on/off of the IGBT in the inverter. Normally the maximum surge voltage is three times the inverter’s input power supply voltage. Be sure the motor withstand voltage is high than the maximum surge voltage.
- (7) If the inverter produces interference to other devices.
 - 1) Lower the carrier frequency.
 - 2) Add a nose filter on the power supply input side.
 - 3) Add a noise filter on the output side of the inverter.
 - 4) Confirm the inverter and motor in good earth-connection status.
 - 5) Have the wires shielded.
 - 6) Get the main circuit wires and the control circuit wires separated.

- (8) If the inverter detects over current when the output load is fan.
- 1) Get “DC braking” valid at starting.
 - 2) If “DC braking” is already valid, please increase the DC braking value.
- (9) If there is Mechanical Vibration
- 1) There may be resonance between the mechanical system’s characteristic frequency and the carrier frequency.
 - 2) There may be resonance between a machine characteristic frequency and the output frequency of the inverter.
- To prevent this, either use the jump frequency functions or install rubber padding on the motor base to reduce vibration.

11. Peripheral devices and specification of options

11.1 Peripheral Devices

Name	Purpose and descriptions
NFB or Ground fault interrupter	Protect inverter wiring. Always connect a breaker to the power supply line to protect inverter wiring. Use a ground fault interrupter suitable for high frequencies.
Magnetic contactor	Prevent burning when a Braking Resistor is used. Always attach a surge absorber to the coil.
Surge absorber	Absorb surge from the magnetic contactor and control relays.
Isolator	Isolate the I/O signals of the inverter and is effective to reduce to interference to other electric devices.
DC Reactor	Used to improve the input power factor of the inverter.
AC Reactor	Used to improve the input power factor of the inverter.
Braking resistor ,braking resistor unit	Consume the regenerative energy of the motor and reduce deceleration time.

11.2 Proper specifications of options.

11.2.1 DC Reactor

Model	Currenty (A)	Inductance (mH)	Model	Currenty (A)	Inductance (mH)
001143B	40	1.10	009043B	238	0.29
001543B	50	1.00	011043B	291	0.24
18D43B	65	0.92	013243B	326	0.215
002243B	70	0.90	016043B	395	0.177
003043B	80	0.86	018543B	494	0.142
003743B	100	0.70	020043B	557	0.126
004543B	120	0.58	022043B	700	0.10
005543B	146	0.47	030043B	800	0.08
007543B	200	0.35			

11.2.2 Input AC Reactor

Model	Currenty (A)	Inductance (mA)
00D423B	2.5	4.2
0D7523B	5	2.1
01D523B	10	1.1
02D223B	15	0.7
0D7543B	2.5	8.4
01D543B	3.7	2.239
02D243B	5.5	2.18
03D743B	9	1.85
05D543B	13	1.56
07D543B	18	1.0
001143B	24	0.52
001543B	34	0.397
18D543B	38	0.352
002243B	50	0.26
003043B	60	0.24
003743B	75	0.235
004543B	91	0.17
005543B	112	0.16

007543B	150	0.12
009043B	180	0.10
011043B	220	0.09
013243B	265	0.08
016043B	300	0.07
018543B	360	0.06
020043B	400	0.05
022043B	560	0.03
030043B	640	0.215

11.2.3 Output AC Reactor

	Model	Current (A)	Inductance (uA)
400V Class	0D7543B	3.0	2100
	01D543B	3.0	2100
	02D243B	6.3	1450
	03D743B	11	1100
	05D543B	16	800
	07D543B	18	650
	001143B	28	330
	001543B	35	250
	18D543B	40	200
	002243B	50	180
	003043B	63	90
	003743B	80	80
	004543B	60	60
	005543B	40	40
	007543B	35	35
	009043B	30	30
	011043B	20	20
	013243B	16	16
016043B	13	13	
018543B	11	11	

	020043B	9	9
	022043B	8	8
	030043B	6	6

11.2.4 Braking resistor

Model	Specifications of braking resistor		Braking torque 10%ED	Motor power (KW)
	W	Ω		
HC1A00D423B	80	200	125	0.4
HC1A0D7523B	100	200	125	0.75
HC1A01D523B	300	100	125	1.5
HC1A02D223B	300	70	125	2.2
HC1A0D7543B	80	750	125	0.75
HC1A01D543B	300	400	125	1.5
HC1A02D243B	300	250	125	2.2
HC1A03D743B	400	150	125	3.7
HC1A05D543B	500	100	125	5.5
HC1A07D543B	1000	75	125	7.5
HC1A001143B	1000	50	125	11
HC1A001543B	1500	40	125	15
HC1A18D543B	4800	32	125	18.5
HC1A002243B	4800	27.2	125	22
HC1A003043B	6000	20	125	30
HC1A003743B	9600	16	125	37
HC1A004543B	9600	13.6	125	45
HC1A005543B	12000	20/2	125	55
HC1A007543B	18000	13.6/2	125	75
HC1A009043B	18000	20/3	125	90
HC1A011043B	18000	20/3	125	110
HC1A013243B	24000	20/4	125	132
HC1A016043B	36000	13.6/4	125	160
HC1A018543B	38400	13.6/4	125	185
HC1A020043B	45000	13.6/5	125	200
HC1A022043B	48000	13.6/5	125	220
HC1A030043B	57600	13.6/6	125	300

Braking resistor unit should be installed for inverters of 11KW or above.

12 Appendices

(1) Mounting Dimensions of inverters

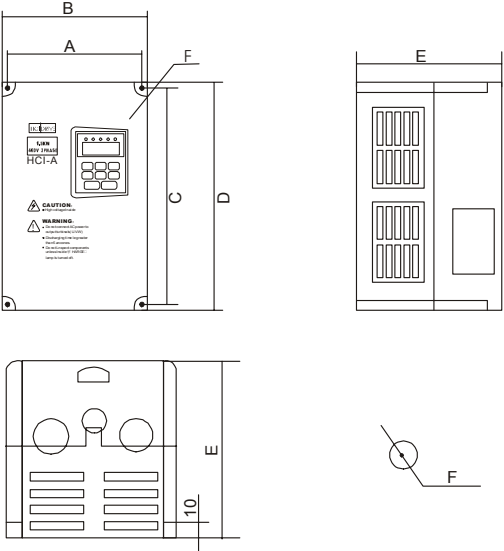
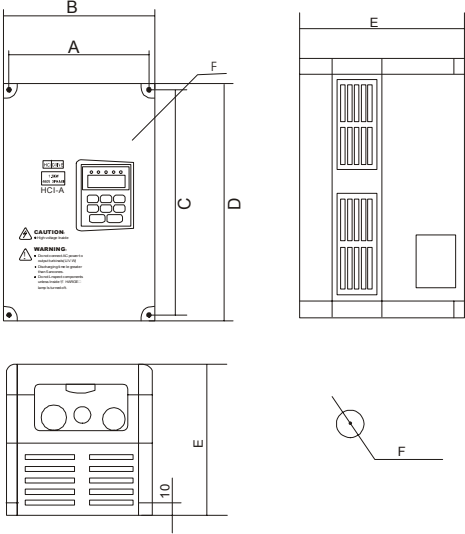
Model	Mounting Dimensions
<p>HC1A00D423B HC1A01D523B HC1A0D7543B HC1A02D243B</p>	 <p style="text-align: right;">unit: mm</p>
<p>HC1A02D223B HC1A03D743B</p>	 <p style="text-align: right;">unit: mm</p>

<p>HC1A05D543B HC1A07D543B</p>	<p>CAUTION: * High temperature</p> <p>WARNING: * Do not touch the surface * Do not touch the display * Do not touch the buttons * Do not touch the fan</p> <p style="text-align: right;">unit: mm</p>
<p>HC1A001143B HC1A004543B</p>	<p>CAUTION: * High temperature</p> <p>WARNING: * Do not touch the surface * Do not touch the display * Do not touch the buttons * Do not touch the fan</p> <p style="text-align: right;">unit: mm</p>

(2) Specifications

Model	A	B	C	D	E	F	G
HC1A00D423B	116	125	161	170	141	Φ 5	
HC1A0D7523B							
HC1A01D523B							
HC1A07D543B							
HC1A01D543B							
HC1A02D243B							
HC1A02D223B HC1A03D743B	128	140	238	250	157	Φ 5	
HC1A05D543B HC1A07D543B	184	200	306	318	183	Φ 6	6
HC1A001143B HC1A001543B	182	253	437	457	241	Φ 8	8
HC1A18D543B HC1A002243B	206	277	490	510	241	Φ 8	8
HC1A003043B	239	311	490	510	241	Φ 8	8
HC1A003743B HC1A004543B HC1A005543B	250	341	650	670	326	Φ 10	10
HPA007543B	300	450	768	800	350	Φ 16	16
HPA009043B	300	450	768	800	350	Φ 16	16
HC1A011043B HC1A013243B HC1A016043B	500	650	868	900	400	Φ 16	16

(2) Mounting Dimensions of Digital Operator

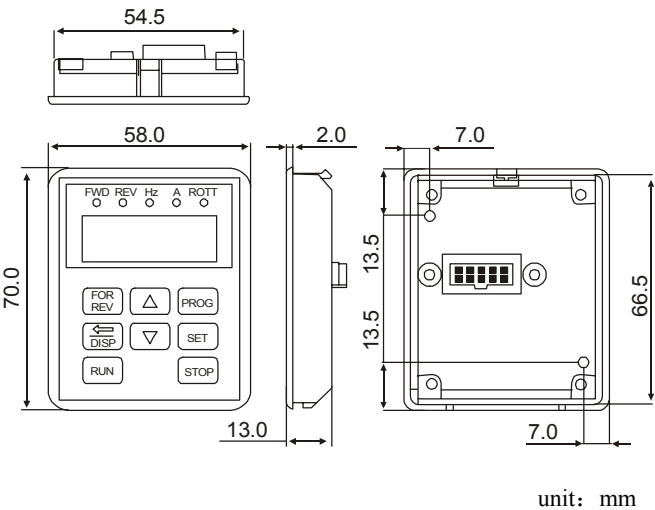
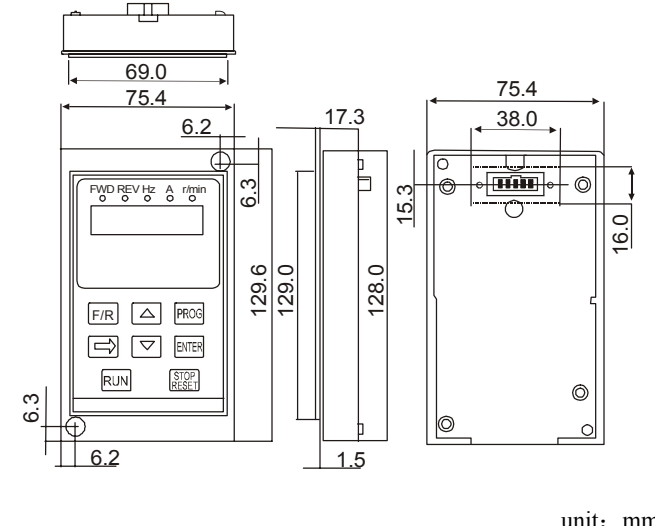
Model	Mounting Dimensions
<p>HC001</p>	 <p style="text-align: right;">unit: mm</p>
<p>HC002</p>	 <p style="text-align: right;">unit: mm</p>

No.4 Users' feedback

Function code	Function	Factory setting	Function code	Function	Factory setting
CD000	Main frequency	0.00	CD046	Skip frequency 3	0.00
CD001	Max output voltage	220/400	CD047	Skip frequency range	0.5
CD002	Base frequency	50.00	CD048~ CD049	Reserved	
CD003	Voltage at medium frequency	15/27.5	CD050	Multi-input 1	02
CD004	Medium frequency	2.50	CD051	Multi- input 2	03
CD005	Voltage at lowest frequency	8.0/13.5	CD052	Multi- input 3	10
CD006	Lowest frequency	0.50	CD053	Multi- input 4	17
CD007	Max operating frequency	50.00	CD054	Multi- input 5	18
CD008	Frequency upper limit	50.00	CD055	Multi- input 6	19
CD009	Frequency lower limit	0.00	CD056	Multi- output 1	01
CD010	Parameter lock select	0	CD057	Multi- output 2	05
CD011	Factory setting	00	CD058	Multi- output 3	02
CD012	Accel.time 1	10.0/25.0	CD059	Multi- output 4	00
CD013	Decel.time 1	10.0/25.0	CD060	Multi- output 5	1
CD014	Accel.time 2	50.0	CD061	Up-to desired frequency 1 setting	0.00
CD015	Decel.time 2	50.0	CD062	Up-to desired frequency 2 setting	0.00
CD016	Accel.time 3	100.0	CD063	Up-to frequency setting detection width	0.50
CD017	Decel.time 3	100.0	CD064	Counter set	00
CD018	Accel.time 4	200.0	CD065	Analog input select	0
CD019	Decel.time 4	200.0	CD066	Lower analog frequency set point	0
CD020~ CD030	Reserved		CD067	Lower analog frequency bias direction	0
CD031	Start mode	0	CD068	Higher analog frequency set point	50.00
CD032	Stop mode	0	CD069	Higher analog frequency bias direction	0
CD033	Control mode select	0	CD070	Negative bias reverse select	1
CD034	Frequency command method select	0	CD071	Analog output gain	100
CD035	Carrier frequency	5	CD072	Up/down function select	1
CD036	Jog frequency	5.00	CD073~ CD075	Reserved	
CD037	FOR/REV select	1	CD076	PLC mode select	0
CD038	“STOP” key definition	1	CD077	Auto PLC select	0
CD039~ CD040	Reserved		CD078	PLC running direction	0

Function code	Function	Factory setting	Function code	Function	Factory setting
CD041	Starting frequency	0.5	CD079	PLC accel./decel.time	0
CD042	Stopping frequency	0.5	CD080	Multi-speed2	15.00
CD043	Torque boost	2.0	CD081	Multi-speed3	20.00
CD044	Skip frequency 1	0.00	CD082	Multi-speed4	25.00
CD045	Skip frequency 2	0.00	CD083	Multi-speed5	30.00
CD084	Multi-speed6	35.00	CD146	Power loss time allowable	0.5
CD085	Multi-speed7	40.00	CD147	Number of auto restart attempt	00
CD086	Multi-speed8	0.50	CD148	Auto voltage regulation	1
CD087	Timer 1	10.0	CD149	Auto energy saving	0
CD088	Timer 2	10.0	CD150	P	100%
CD089	Timer 3	0.0	CD151	I	5.0
CD090	Timer 4	0.0	CD152	D	0
CD091	Timer 5	0.0	CD153	Target value	
CD092	Timer 6	0.0	CD154	Target value source	
CD093	Timer 7	0.0	CD155	PID upper limit	100%
CD094	Timer 8	0.0	CD156	PID lower limit	0%
CD095~ CD119	Reserved		CD157~ CD159	Reserved	
CD120	Stall prevention select	1	CD160	Communication identified no.	0
CD121	Stall prevention level during accel	150	CD161	Baud rate of communication	1
CD122	Stall prevention level during running	0	CD162	Communication agreement	0
CD123	Stall prevention level during decek	150	CD163~ CD167	Reserved	
CD124	Reserved		CD168	Display mode	00
CD125	Over torque detection level	0	CD169	Rated voltage of the inverter	*
CD126	Over torque detection time	1.0	CD170	Rated current of the inverter	*
CD127~ CD129	Reserved		CD171	Software version	*
CD130	Rated voltage	*	CD172	Fault record 1	—
CD131	Rated current	*	CD173	Fault record 2	—
CD132	Motor poles	04	CD174	Fault record 3	—
CD133	Rated rotating speed	1440	CD175	Fault record 4	—

Function code	Function	Factory setting	Function code	Function	Factory setting
CD134~ CD139	Reserved		CD176	Fault cleared	00
CD140	DC braking level	2.0	CD177	Reserved	
CD141	DC braking time at starting	0.0	CD178	Frequency standard of the inverter	0
CD142	DC braking time at stopping	0.0	CD179	Manu faction date	*
CD143	Speed search time	5.0	CD180	Sequence number	*
CD144	Speed search current level	150	CD181~ CD250	Reserved	
CD145		0			

TECORP ELECTRONICS CO., LTD.

3F-3, No.12, Lane 609, Sec.5, Chung Hsin Rd.,
San Chung, Taipei County, Taiwan, R.O.C.

Tel : +886-2-29991466

Fax: +886-2-29992691

E-mail: top2@tecorp-group.com

[Http://www.tecorp-group.com](http://www.tecorp-group.com)

Copyright by: TECORP ELECTRONICS CO., LTD.